

Programmable AC/DC Electronic Load

Programming Guide for IT8600 Series

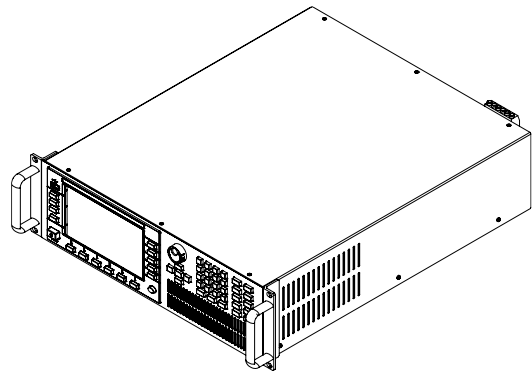

Model: IT8615/IT8615L/IT8616/IT8617
/IT8624/IT8625/IT8626/IT8627/IT8628
Version: V2.3

Notices

© ItechElectronic, Co., Ltd. 2019
No part of this manual may be reproduced in any form or by any means (including electronic storage and retrieval or translation into a foreign language) without prior permission and written consent from Itech Electronic, Co., Ltd. as governed by international copyright laws.

Manual Part Number

IT8600-402266

Revision

2nd Edition: Feb. 20, 2019
Itech Electronic, Co., Ltd.

Trademarks

Pentium is U.S. registered trademarks of Intel Corporation.

Microsoft, Visual Studio, Windows and MS Windows are registered trademarks of Microsoft Corporation in the United States and/or other countries and regions.

Warranty

The materials contained in this document are provided "as is", and is subject to change, without prior notice, in future editions. Further, to the maximum extent permitted by applicable laws, ITECH disclaims all warranties, either express or implied, with regard to this manual and any information contained herein, including but not limited to the implied warranties of merchantability and fitness for a particular purpose. ITECH shall not be held liable for errors or for incidental or indirect damages in connection with the furnishing, use or application of this document or of any information contained herein. Should ITECH and the user enter into a separate written agreement with warranty terms covering the materials in this document that conflict with these terms, the warranty terms in the separate agreement shall prevail.

Technology Licenses

The hardware and/or software described herein are furnished under a license and may be used or copied only in accordance with the terms of such license.

Restricted Rights Legend

U.S. Government Restricted Rights. Software and technical data rights granted to the federal government include only those rights customarily provided to end user customers. ITECH provides this customary commercial license in software and technical data pursuant to FAR 12.211 (Technical Data) and 12.212 (Computer Software) and, for the Department of Defense, DFARS 252.227-7015 (Technical Data – Commercial Items) and DFARS 227.7202-3 (Rights in Commercial Computer Software or Computer Software Documentation).

Safety Notices

CAUTION

A CAUTION sign denotes a hazard. It calls attention to an operating procedure or practice that, if not correctly performed or adhered to, could result in damage to the product or loss of important data. Do not proceed beyond a CAUTION sign until the indicated conditions are fully understood and met.

WARNING

A WARNING sign denotes a hazard. It calls attention to an operating procedure or practice that, if not correctly performed or adhered to, could result in personal injury or death. Do not proceed beyond a WARNING sign until the indicated conditions are fully understood and met.



NOTE

A NOTE sign denotes important hint. It calls attention to tips or supplementary information that is essential for users to refer to.

Quality Certification and Assurance

We certify that series IT8600 electronic load meets all the published specifications.

Warranty

ITECH warrants that the product will be free from defects in material and workmanship under normal use for a period of one (1) year from the date of delivery (except those described in the Limitation of Warranty below). For warranty service or repair, the product must be returned to a service center designated by ITECH.















- The product returned to ITECH for warranty service must be shipped PREPAID. And ITECH will pay for return of the product to customer.
- If the product is returned to ITECH for warranty service from overseas, all the freights, duties and other taxes shall be on the account of customer.

Limitation of Warranty

This Warranty will be rendered invalid if the product is:

- Damaged resulting from customer-wired circuits or customer-supplied parts or accessories;
- Modified or repaired by customer without authorization;
- Damaged resulting from customer-wired circuits or use in an environment not designated by us;
- The product model or serial number is altered, deleted, removed or made illegible by customer;
- Damaged as a result of accidents, including but not limited to lightning, moisture, fire, improper use or negligence.

Safety Symbols

	Direct current		ON (power on)
	Alternating current		OFF (power off)
	Both direct and alternating current		Power-on state
	Protective conductor terminal		Power-off state
	Earth (ground) terminal		Reference terminal
	Caution, risk of electric shock		Positive terminal
	Warning, risk of danger (refer to this manual for specific Warning or Caution information)		Negative terminal
	Frame or chassis terminal	-	-

Safety Precautions

The following safety precautions must be observed during all phases of operation of this instrument. Failure to comply with these precautions or specific warnings elsewhere in this manual will constitute a default under safety standards of design, manufacture and intended use of the instrument. ITECH assumes no liability for the customer's failure to comply with these precautions.

WARNING

- Do not use the instrument if it is damaged. Before operation, check the casing to see whether it cracks. Do not operate the instrument in the presence of inflammable gasses, vapors or dusts.
- The electronic load is provided with a three-core power line during delivery and should be connected to a three-core junction box. Before operation, be sure that the electronic load is well grounded.
- Make sure to use the power cord supplied by ITECH.
- Check all marks on the instrument before connecting the instrument to power supply.
- Use electric wires of appropriate load. All loading wires should be capable of bearing maximum short-circuit of electronic load without overheating. If there are multiple loads, each pair of the load power cord must be carry out the full rated short-circuit output current of the power securely.
- Ensure the voltage fluctuation of mains supply is less than 10% of the working voltage range in order to reduce risks of fire and electric shock.
- Do not install alternative parts on the instrument or perform any unauthorized modification.
- Do not use the instrument if the detachable cover is removed or loose.
- To prevent the possibility of accidental injuries, be sure to use the power adapter supplied by the manufacturer only.
- We do not accept responsibility for any direct or indirect financial damage or loss of profit that might occur when using the instrument.
- This instrument is used for industrial purposes, Do not apply this product to IT power supply system.
- Never use the instrument with a life-support system or any other equipment subject to safety requirements.

CAUTION

- Failure to use the instrument as directed by the manufacturer may render its protective features void.
- Always clean the casing with a dry cloth. Do not clean the internals.
- Make sure the vent hole is always unblocked.

Environmental Conditions

The instrument is designed for indoor use and an area with low condensation. The table below shows the general environmental requirements for the instrument.

Environmental Conditions	Requirements
Operating temperature	5°C-40°C
Operating humidity	humidity 20%-80% (non-condensation)



Storage temperature	-20°C-50 °C
Altitude	≤2,000m
Installation category	II
Pollution degree	Pollution degree 2



NOTE

To make accurate measurements, allow the instrument to warm up for 30 min.

Regulatory Marking

	The CE mark indicates that the product complies with all the relevant European legal directives. The specific year (if any) affixed refers to the year when the design was approved.
	The instrument complies with the WEEE Directive (2002/96/EC) marking requirement. This affixed product label indicates that you must not discard the electrical/electronic product in domestic household waste.
	This symbol indicates the time period during which no hazardous or toxic substances are expected to leak or deteriorate during normal use. The expected useful service of the product is 10 years. The product can be used safely during the 10-year Environment Friendly Use Period (EFUP). Upon expiration of the EFUP, the product must be immediately recycled.

Waste Electrical and Electronic Equipment (WEEE) Directive



2002/96/EC Waste Electrical and Electronic Equipment (WEEE) Directive

This product complies with the WEEE Directive (2002/96/EC) marking requirement. This affix product label indicates that you must not discard the electrical/electronic product in domestic household waste.

Product Category

With reference to the equipment classifications described in the Annex I of the WEEE Directive, this instrument is classified as a ."Monitoring and Control Instrument".

To return this unwanted instrument, contact your nearest ITECH office.

Compliance Information

Complies with the essential requirements of the following applicable European Directives, and carries the CE marking accordingly:

- Electromagnetic Compatibility (EMC) Directive 2014/30/EU
- Low-Voltage Directive (Safety) 2014/35/EU

Conforms with the following product standards:

EMC Standard

IEC 61326-1:2012/ EN 61326-1:2013 ¹²³

Reference Standards

CISPR 11:2009+A1:2010/ EN 55011:2009+A1:2010 (Group 1, Class A)

IEC 61000-4-2:2008/ EN 61000-4-2:2009

IEC 61000-4-3:2006+A1:2007+A2:2010/ EN 61000-4-3:2006+A1:2008+A2:2010

IEC 61000-4-4:2004+A1:2010/ EN 61000-4-4:2004+A1:2010

IEC 61000-4-5:2005/ EN 61000-4-5:2006

IEC 61000-4-6:2008/ EN 61000-4-6:2009

IEC 61000-4-11:2004/ EN 61000-4-11:2004

1. The product is intended for use in non-residential/non-domestic environments. Use of the product in residential/domestic environments may cause electromagnetic interference.
2. Connection of the instrument to a test object may produce radiations beyond the specified limit.
3. Use high-performance shielded interface cable to ensure conformity with the EMC standards listed above.

Safety Standard

IEC 61010-1:2010/ EN 61010-1:2010

CONTENT

Quality Certification and Assurance	i
Warranty	i
Limitation of Warranty	i
Safety Symbols	i
Safety Precautions	ii
Environmental Conditions	ii
Regulatory Marking	iii
Waste Electrical and Electronic Equipment (WEEE) Directive	iii
Compliance Information	iv
Chapter1 SCPI Introduction	1
1.1 Overview	1
1.2 Command Type of SCPI	1
1.3 Message Type of SCPI	4
1.4 Response Data Type	5
1.5 Command Format	6
1.6 Data Type	9
1.7 Remote Interface Connections	10
Chapter2 Measurement Commands	11
MEASure?	11
FETCh?	11
MEASure:CURRent?	11
FETCh:CURRent?	11
MEASure:CURRent:RMS?	12
FETCh:CURRent:RMS?	12
MEASure:CURRent:MAXimum?	12
FETCh:CURRent:MAXimum?	12
MEASure:CURRent:CFACTOR?	12
FETCh:CURRent:CFACTOR?	12
MEASure:CURRent:MINPeak?	13
FETCh:CURRent:MINPeak?	13
MEASure:CURRent:MAXPeak?	13
FETCh:CURRent:MAXPeak?	13
MEASure:FREQuency?	13
FETCh:FREQuency?	13
MEASure:POWer?	14
FETCh:POWer?	14
MEASure:POWer:MAXimum?	14
FETCh:POWer:MAXimum?	14
MEASure:POWer:APParent?	14
FETCh:POWer:APParent?	14
MEASure:POWer:PFACTOR?	15
FETCh:POWer:PFACTOR?	15
MEASure:POWer:REACTIVE?	15
FETCh:POWer:REACTIVE?	15

MEASure:RESistance?	15
FETCh:RESistance?	15
MEASure:VOLTagE?	16
FETCh:VOLTagE?	16
MEASure:VOLTagE:RMS?	16
FETCh:VOLTagE:RMS?	16
MEASure:VOLTagE:MAXimum?	16
FETCh:VOLTagE:MAXimum?	16
MEASure:VOLTagE:THDistort?	17
FETCh:VOLTagE:THDistort?	17
MEASure:ETIME?	17
FETCh:ETIME?	17
MEASure:TEMPerature?	17
FETCh:TEMPerature?	17
MEASure:CURRent:AMPLitude:HOLD	17
MEASure:HARMonic?	18
MEASure:VOLTagE:HARMonic?	18
MEASure:PHASe:HARMonic?	19
MEASure:VOLTagE:HARMonic:DISort?	19
FETCh:VOLTagE:HARMonic?	19
FETCh:PHASe:HARMonic?	20
FETCh:VOLTagE:HARMonic:DISort?	20
FETCh:HARMonic?	20
Chapter3 Load Commands	22
INPut	22
INPut:REAL?	22
FUNcTion	22
INPut:SHORt	23
INPut:SHORt:FUNcTion	23
[SOURce:]PROTection:CLEar	24
PROTection:AUTO:CLEar	24
[SOURce:]LOOP:MODE <CC CR>	24
CURRent	25
[SOURce:]CURRent:LIMit[:LEVel][:CV]	25
CURRent:PROTection	26
CURRent:PEAK:PROTection	27
CURRent:PROTection:DELay	27
CURRent:PROTection:STATe	28
POWer	28
[SOURce:]POWer:MAXimum[:LEVel]	28
POWer:PROTection	29
POWer:PROTection:DELay	29
POWer:PROTection:STATe	30
RESistance	30
VOLTagE	31

CFACTor	31
PFACTor	32
INPut:TIMer	32
INPut:TIMer:DELay	33
MEASure:TYPE	33
RATE:DCCV	34
RATE:CC	34
WAVE:TRIGger:VOLTage[:LEVel]	35
WAVE:TRIGger:CURRent[:LEVel]	35
WAVE:TRIGger:SOURce	36
WAVE:TRIGger:SLOPe	36
WAVE:TRIGger:MODE	36
WAVE:TRIGger:DELay:TIME	37
WAVE:TRIGger:DIVTime	37
WAVE:RUN	38
WAVE:STOP	38
WAVE:SINGle	38
WAVE:VOLTage:DATA?	39
WAVE:CURRent:DATA?	39
WAVE:TRIGger?.....	39
WAVE:SCOPE:SELECTION	40
WAVE:KNOB:SELECTION.....	40
WAVE:VOLTage:BASE	40
WAVE:VOLTage:RANGe	41
WAVE:CURRent:BASE	41
WAVE:CURRent:RANGe	42
PORT:OUTPut	42
AVERage:COUNT	43
PARAllel:SETup:SElect	43
PARAllel:VIEW:SElect	43
PARAllel:BALance[:STATe].....	44
Chapter4 System Commands.....	45
SYSTem:MODE	45
SYSTem:CFPF:MODE	45
SYSTem:CFPF:PRIOrity	45
SYSTem:HARMonic:FORMula.....	46
SYSTem:COMMunicate:GPIB:ADDress	46
SYSTem:COMMunicate:LAN:CURRent:ADDress	47
SYSTem:COMMunicate:LAN:CURRent:DGATeway	47
SYSTem:COMMunicate:LAN:CURRent:SMASK	48
SYSTem:COMMunicate:LAN:DHCP	48
SYSTem:COMMunicate:LAN:SOCKetport	49
SYSTem:COMMunicate:LAN:MACaddress?	49
SYSTem:BEEPer:IMMEDIATE	50
SYSTem:BEEPer.....	50

SYSTem:VERSiOn?	50
SYSTem:ERRor?	51
SYSTem:REMOte	51
SYSTem:LOCal.....	51
SYSTem:RWLock.....	52
SYSTem:BACKlight:BRIGHtness	52
Chapter5 Status Commands.....	53
STATus:QUEStionable?	53
STATus:QUEStionable:CONDition?	53
STATus:QUEStionable:ENABle	53
STATus:OPERation?.....	54
STATus:OPERation:CONDition?	55
STATus:OPERation:ENABle	55
Chapter6 Common Commands.....	57
*CLS	57
*ESE	57
*ESR?	58
*IDN?.....	58
*OPC	58
*RST	59
*SRE.....	59
*STB	60
*SAV	60
*RCL.....	61
*TST?	61
Appendix.....	62

Chapter1 SCPI Introduction

1.1 Overview

SCPI is short for Standard Commands for Programmable Instruments which defines a communication method of bus controller and instrument. It is based on ASCII and supply for testing and measuring instruments. SCPI command is based on hierarchical architecture which also known as tree system. In this system, Relevant Command is returned to a common node or root, so that a subsystem is formed. A part of OUTPut subsystem is listed below:

OUTPut:

- **SYNC {OFF|0|ON|1}**
- **SYNC:**
- **MODE {NORMAl|CARRier}**
- **POLarity {NORMAl|INVerted}**

OUTPut is the root class keyword, SYNC is the second keyword, MODE and POLarity are the third keyword. Colon(:) is used for separating the command keyword and the next level keyword.

1.2 Command Type of SCPI

SCPI has two types of commands, common and subsystem.

- Common commands generally are not related to specific operation but to controlling overall instrument functions, such as reset, status, and synchronization. All common commands consist of a three-letter mnemonic preceded by an asterisk: ***RST *IDN? *SRE 8**.
- Subsystem commands perform specific instrument functions. They are organized into an inverted tree structure with the "root" at the top. The following figure shows a portion of a subsystem command tree, from which you access the commands located along the various paths.

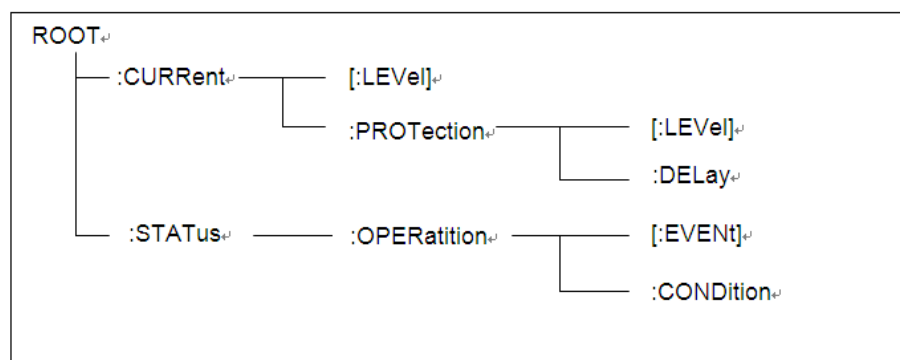

Multiple Commands in a Message

Multiple SCPI commands can be combined and sent as a single message with one message terminator. There are two important considerations when sending several commands within a single message:

- Use a semicolon to separate commands within a message.
- Head paths influence how the instrument interprets commands.

We consider the head path as a string which will be inserted in front of every command of a message. As for the first command of a message, the head path is a null string; for each subsequent command, the head path is a string which is defined to form the current command until and including the head of the last colon separator. A message with two combined commands:

CURR:LEV 3;PROT:STAT OFF

The example indicates the effect of semicolon and explains the concept of head path. Since the head path is defined to be "CURR" after "curr: lev 3", the head of the second command, "curr", is deleted and the instrument explains the second command as:

CURR:PROT:STAT OFF

If "curr" is explicitly included in the second command, it is semantically wrong. Since combining it with the head path will become "CURR:CURR:PROT:STAT OFF", resulting in wrong command.

Movement in the Subsystem

In order to combine commands from different subsystems, you need to be able to reset the header path to a null string within a message. You do this by beginning the command with a colon (:), which discards any previous header path. For example, you could clear the output protection and check the status of the Operation Condition register in one message by using a root specifier as follows:

PROTection:CLEAr;;STATus:OPERation:CONDition?

The following message shows how to combine commands from different subsystems as well as within the same subsystem:

POWEr:LEVel 200;PROTection 28; :CURRent:LEVel 3;PROTection:STATe ON

Note the use of the optional header LEVel to maintain the correct path within the voltage and current subsystems, and the use of the root specifier to move between subsystems.

Including Common Commands

You can combine common commands with subsystem commands in the same message. Treat the common command as a message unit by separating it with a semicolon (the message unit separator). Common commands do not affect the header path; you may insert them anywhere in the message.

VOLTage:TRIGgered 17.5::INITialize;*TRG

OUTPut OFF;*RCL 2;OUTPut ON

Case Sensitivity

Common commands and SCPI commands are not case sensitive. You can use upper or lower, for example:

***RST = *rst**

:DATA? = :data?

:SYSTem:PRESet = :system:preset

Long-Form and Short-Form Versions

A SCPI command word can be sent in its long-form or short-form version. However, the short-form version is indicated by upper case characters. Examples:

:SYSTem:PRESet long-form

:SYST:PRES short form

:SYSTem:PRES long-form and short-form combination

Note that each command word must be in long-form or short-form, and not something in between.

For example, **:SYSTe:PRESe** is illegal and will generate an error. The command will not be executed.

Query

Observe the following precautions with queries:

- Set up the proper number of variables for the returned data. For example, if you are reading back a measurement array, you must dimension the array according to the number of measurements that you have placed in the measurement buffer.
- Read back all the results of a query before sending another command to the instrument. Otherwise a Query Interrupted error will occur and the unreturned data will be lost.

1.3 Message Type of SCPI

There are two types of SCPI messages, program and response.

- Program message: A program message consists of one or more properly formatted SCPI commands sent from the controller to the instrument. The message, which may be sent at any time, requests the instrument to perform some action.
- Response message: A response message consists of data in a specific SCPI format sent from the instrument to the controller. The instrument sends the message only when commanded by a program message called a "query."

The next figure illustrates SCPI message structure:

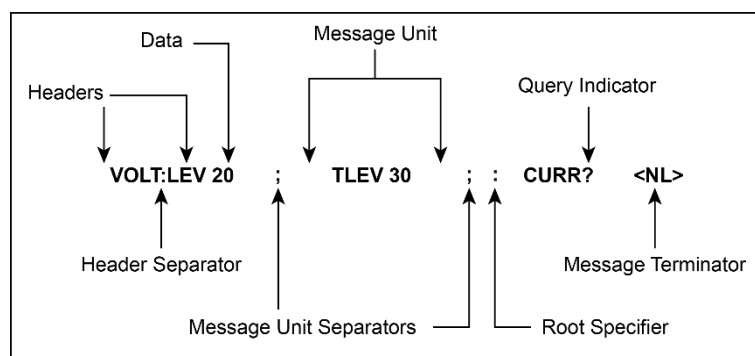

The message unit

The simplest SCPI command is a single message unit consisting of a command header (or keyword) followed by a message terminator. The message unit may include a parameter after the header. The parameter can be numeric or a string.

ABORt<NL>

VOLTage 20<NL>

Headers

Headers, also referred to as keywords, are instructions recognized by the instrument. Headers may be either in the long form or the short form. In the long form, the header is completely spelled out, such as VOLTAGE, STATUS and DELAY. In the short form, the header has only the first three or four letters, such as VOLT, STAT and DEL.

Query indicator

Following a header with a question mark turns it into a query (**VOLTage?**, **VOLTage:PROtection?**). If a query contains a parameter, place the query indicator at the end of the last header (**VOLTage:PROtection?MAX**).

Message unit separator

When two or more message units are combined into a compound message, separate the units with a semicolon (**STATUS:OPERation?;QUESTionable?**).

Root specifier

When it precedes the first header of a message unit, the colon becomes the root specifier. It tells the command parser that this is the root or the top node of the command tree.

Message terminator

A terminator informs SCPI that it has reached the end of a message. Three permitted message terminators are:

- newline (<NL>), decimal 10 or hexadecimal 0X0A in ASCII.
- end or identify (<END>)
- both of the above (<NL><END>).

In the examples of this guide, there is an assumed message terminator at the end of each message.

Command execution rules

- Commands execute in the order that they are presented in the program message.
- An invalid command generates an error and, of course, is not executed.
- Valid commands that precede an invalid command in a multiple command program message are executed.
- Valid commands that follow an invalid command in a multiple command program message are ignored.

1.4 Response Data Type

Character strings returned by query statements may take either of the following forms, depending on the length of the returned string:

- **<CRD>**: character response data. Permits the return of character strings.
- **<AARD>**: arbitrary ASCII response data. Permits the return of unlimited 7-bit ASCII. This data type has an implied message terminator.
- **<SRD>**: string response data. Returns string parameters enclosed in double quotes.
- **<Block>**: arbitrary block data.

Response messages

A response message is the message sent by the instrument to the computer in response to a query command.

Sending a response message

After sending a query command, the response message is placed in the Output Queue. When the instrument is then addressed to talk, the response message is sent from the Output Queue to the computer

Multiple response messages

If you send more than one query command in the same program message, the multiple response messages for all the queries is sent to the computer when the instrument is addressed to talk. The responses are sent in the order that the query commands were sent and are separated by semicolons (;). Items within the same query are separated by commas (.). The following example shows the response message for a program message that contains four single item query commands:

```
0; 1; 1; 0
```

Response message terminator (RMT)

Each response is terminated with an LF (line feed) and EOI (end or identify). The following example shows how a multiple response message is terminated:

```
0; 1; 1; 0; <RMT>
```

Message exchange protocol

Two rules summarize the message exchange protocol:

- **Rule 1:** You must always tell the instrument what to send to the computer.
The following two steps must always be performed to send information from the instrument other computer:
 1. Send the appropriate query command(s) in a program message.
 2. Address the instrument to talk.
- **Rule 2:** The complete response message must be received by the computer before another program message can be sent to the instrument.

1.5 Command Format

Formats for command display are as follows:

```
[SOURce[1|2]:]VOLTage:UNIT {VPP|VRMS|DBM}
```

```
[SOURce[1|2]:]FREQuency:CENTer  
{<frequency>|MINimum|MAXimum|DEFault}
```

Based on the command syntax, most commands (and certain Parameter) are expressed in both upper and lower cases. Upper case refers to abbreviation of commands. Shorter program line may send commands in abbreviated format. Long-format commands may be sent to ensure better program readability.

For example, both formats of VOLT and VOLTAGE are acceptable in the above

syntax statements. Upper or lower case may be used. Therefore, formats of VOLTAGE, volt and Volt are all acceptable. Other formats (such as VOL and VOLTAG) are invalid and will cause errors.

- Parameter options with given command strings are included in the brace ({ }). The brace is not sent along with command strings.
- Vertical stripes (|) separate several parameter options with given command strings. For example, {VPP|VRMS|DBM} indicates that you may assign "APP", "VRMS" or "DBM" in the above commands. Vertical stripes are not sent along with command strings.
- Angle brackets (< >) in the second example indicates that a value must be assigned to the parameter in the brace. For example, the parameter in the angle bracket is <frequency> in the above syntax statements. Angle brackets are not sent along with command strings. You must assign a value (such as "FREQ:CENT 1000") to the parameter, unless you select other options displayed in the syntax (such as "FREQ:CENT MIN").
- Some syntax elements (such as nodes and Parameter) are included in square brackets ([]). It indicates that these elements can be selected and omitted. Angle brackets are not sent along with command strings. If no value is assigned to the optional Parameter, the instrument will select a default value. In the above examples, "SOURce[1|2]" indicates that you may refer to source channel 1 by "SOURce" or "SOURce1" or "SOUR1" or "SOUR". In addition, since the whole SOURce node is optional (in the square bracket), you can refer to the channel 1 by omitting the whole SOURce node. It is because the channel 1 is the default channel for SOURce language node. On the other hand, if you want to refer to channel 2, "SOURce2" or "SOUR2" must be used in the program line.

Colon (:)

It is used to separate key words of a command with the key words in next level. As shown below:

APPL:SIN 455E3,1.15,0.0

In this example, APPLy command assigns a sine wave with frequency of 455 KHz, amplitude of 1.15 V and DC offset of 0.0 V.

Semicolon (;)

It is used to separate several commands in the same subsystem and can also minimize typing. For example, to send the following command string:

TRIG:SOUR EXT; COUNT 10

has the same effect as sending the following two commands:

**TRIG:SOUR EXT
TRIG:COUNT 10**

Question mark (?)

You can insert question marks into a command to query current values of most Parameter. For example, the following commands will trigger to set the count as 10:

TRIG:COUN 10

Then, you may query count value by sending the following command:

TRIG:COUN?

You may also query the allowable minimum or maximum count as follows:

TRIG:COUN?MIN

TRIG:COUN?MAX

Comma (,)

If a command requires several Parameter, then a comma must be used to separate adjacent Parameter.

Space

You must use blank characters, [TAB] or [Space] to separate Parameter with key words of commands.

Common commands (*)

The IEEE-488.2 standard defines a set of common commands that perform functions such as reset, self-test, and status operations. Common commands always start with an asterisk (*) and occupy 3 character sizes, including one or more Parameter. Key words of a command and the first parameter are separated by a space. Semicolon (;) can separate several commands as follows:

***RST; *CLS; *ESE 32; *OPC?**

Command terminator

Command strings sent to the instrument must end with a <Newline> (<NL>) character. IEEE-488 EOI (End or Identify) information can be used as <NL> character to replace termination command string of <NL> character. It is acceptable to place one <NL> after a <Enter>. Termination of command string always resets current SCPI command path to root level.

 NOTE

As for every SCPI message with one query sent to the instrument, the instrument will use a <NL> or newline sign (EOI) to terminate response of return. For example, if "DISP:TEXT?" is sent, <NL> will be placed after the returned data string to terminate response. If an SCPI message includes several queries separated by semicolon (such as "DISP?;DISP:TEXT?"), <NL> will terminate response returned after response to the last query. In all cases, the program must read <NL> in response before another command is sent to the instrument, otherwise errors will be caused.

1.6 Data Type

SCPI language defines several data types used for program message and response messages.

- Numerical parameter

Commands requiring numerical parameter support the notations of all common decimal notations, including optional signs, decimal points, scientific notation, etc. Special values of numerical parameter are also acceptable, such as MIN, MAX and DEF. In addition, suffixes for engineering units can also be sent together with numerical parameter (including M, k, m or u). If the command accepts only some specific values, the instrument will automatically round the input parameter to acceptable values. The following commands require numerical parameter of frequency value:

[SOURce[1|2]:]FREQuency:CENTer
{<Frequency>|MINimum|MAXimum}

- <NR1>: represents an integer value, such as 273;
- <NR2>: represents a real number in floating-point format, such as .273;
- <NR3>: represents a real number in scientific notation, such as 2.73E+2;
- <Nrf>: The extensible form includes <NR1>, <NR2> and <NR3>;
- <Nrf+>: The extensible decimal form includes <Nrf>, MIN, MAX and DEF. MIN and MAX are the minimum and maximum finite number. Within the range of the parameter definition, DEF is the default of the parameter.

- Discrete parameter

Discrete parameter are used for settings with limited number of programming values (such as IMMEDIATE, EXTERNAL or BUS). They can use short and long format like key words of commands. They may be expressed in both upper and lower case. The query response always returns uppercase Parameter in short format. The following commands require discrete parameter in voltage unit:

[SOURce[1|2]:]VOLTage:UNIT {VPP|VRMS|DBM}

- Boolean parameter

Boolean parameter refer to true or false binary conditions. In case of false conditions, the instrument will accept "OFF" or "0". In case of true conditions, the instrument will accept "ON" or "1". In query of Boolean settings, the instrument will always return "0" or "1". Boolean parameter are required by the following commands:

DISPlay {OFF|0|ON|1}

- ASCII string parameter

String parameter may actually include all ASCII character sets. Character strings must start and end with paired quotation marks; and single quotation marks or double quotation marks are both allowed. Quotation mark separators may also act as one part of a string, they can be typed twice without any character added between them. String parameter is used in the following command:

DISPlay:TEXT <quoted string>

For example, the following commands display message of "WAITING..." (without quotation marks) on the front panel of the instrument.

DISP:TEXT "WAITING..."

Single quotation marks may also be used to display the same message.

DISP:TEXT 'WAITING...'

– **<SPD>**: string program data. String parameters enclosed in single or double quotes.

– **<CPD>**: character program data.

1.7 Remote Interface Connections

Please refer to user manual for detailed introductions of the remote interface.

Chapter2 Measurement Commands

MEASure?

FETCh?

This command is used to read the measurement value of electronic load.

The sequence of measurement data is listed in the following table:

Measurement Value	Description
CURR_DC	Direct current value
CURR_RMS	Current effective value
CURR_MAX	Current maximum value
CURR_MAXP	The positive peak current
CURR_MINP	The negative peak current
VOLT_DC	Direct voltage value
VOLT_RMS	Voltage effective value
VOLT_MAX	Maximum voltage
POW_ACT	Active power
POW_APP	Apparent power
POW_REAC	Reactive power
POW_MAX	Maximum power
RES	Resistance
FREQ	Frequency
CURR_CFAC	Crest Factor
POW_PFAC	Peak Factor
VOLT_THD	Total harmonic distortion of voltage
ETIME	Elapsed time under timing mode
TEMP	Temperature

Returned value:

<NR3>

MEASure:CURRent?

FETCh:CURRent?

This command is used to read the current average value in load input terminal.

Command syntax:

MEASure[:SCALar]:CURRent[:DC]?

FETCh[:SCALar]:CURRent[:DC]?

Returned value:

<NR3>

MEASure:CURRent:RMS?

FETCh:CURRent:RMS?

This command is used to read the current effective value.

Command syntax:

MEASure[:SCALar]:CURRent:RMS?

FETCh[:SCALar]:CURRent:RMS?

Returned value:

<NR3>

MEASure:CURRent:MAXimum?

FETCh:CURRent:MAXimum?

This command is used to read the maximum current value in load input terminal.

Command syntax:

MEASure[:SCALar]:CURRent[:AMPLitude]:MAXimum?

FETCh[:SCALar]:CURRent[:AMPLitude]:MAXimum?

Returned value:

<NR3>

MEASure:CURRent:CFACTOR?

FETCh:CURRent:CFACTOR?

This command is used to read the crest factor of current.

Command syntax:

MEASure[:SCALar]:CURRent:CFACTOR?

FETCh[:SCALar]:CURRent:CFACTOR?

Returned value:

<NR3>

MEASure:CURRent:MINPeak?

FETCh:CURRent:MINPeak?

This command is used to read the negative peak current of electronic load.

Command syntax:

```
MEASure[SCALar:]CURRent:MINPeak?  
FETCh:[SCALar:]CURRent:MINPeak?
```

Returned value:

<NR3>

MEASure:CURRent:MAXPeak?

FETCh:CURRent:MAXPeak?

This command is used to read the positive peak current of electronic load.

Command syntax:

```
MEASure[:SCALar]:CURRent:MAXPeak?  
FETCh[:SCALar]:CURRent:MAXPeak?
```

Returned value:

<NR3>

MEASure:FREQuency?

FETCh:FREQuency?

This command is used to read the frequency of Hertz as the unit.

Command syntax:

```
MEASure[:SCALar]:FREQuency?  
FETCh[:SCALar]:FREQuency?
```

Returned value:

<NR3>

MEASure:POWer?

FETCh:POWer?

This command is used to read the active power of WATT as the unit.

Command syntax:

```
MEASure[:SCALar]:POWer[:ACTive]?
```

```
FETCh[:SCALar]:POWer[:ACTive]?
```

Returned value:

```
<NR3>
```

MEASure:POWer:MAXimum?

FETCh:POWer:MAXimum?

This command is used to read the maximum input power value.

Command syntax:

```
MEASure[:SCALar]:POWer[:AMPLitude]:MAXimum?
```

```
FETCh[:SCALar]:POWer[:AMPLitude]:MAXimum?
```

Returned value:

```
<NR3>
```

MEASure:POWer:APParent?

FETCh:POWer:APParent?

This command is used to read the apparent power of VA as the unit.

Command syntax:

```
MEASure[:SCALar]:POWer:APParent?
```

```
FETCh[:SCALar]:POWer:APParent?
```

Returned value:

```
<NR3>
```

MEASure:POWer:PFACTOR?

FETCh:POWer:PFACTOR?

This command is used to read the power factor of electronic load.

Command syntax:

```
MEASure[:SCALar]:POWer:PFACTOR?
```

```
FETCh[:SCALar]:POWer:PFACTOR?
```

Returned value:

```
<NR3>
```

MEASure:POWer:REACTive?

FETCh:POWer:REACTive?

This command is used to read the reactive power of VAR as the unit.

Command syntax:

```
MEASure[:SCALar]:POWer:REACTive?
```

```
FETCh[:SCALar]:POWer:REACTive?
```

Returned value:

```
<NR3>
```

MEASure:RESistance?

FETCh:RESistance?

This command is used to read the resistance value of ohm as the unit.

Command syntax:

```
MEASure[:SCALar]:RESistance?
```

```
FETCh[:SCALar]:RESistance?
```

Returned value:

```
<NR3>
```

MEASure:VOLTage?

FETCh:VOLTage?

This command is used to read the voltage value.

Command syntax:

```
MEASure[:SCALar]:VOLTage[:DC]?
```

```
FETCh[:SCALar]:VOLTage[:DC]?
```

Returned value:

```
<NR3>
```

MEASure:VOLTage:RMS?

FETCh:VOLTage:RMS?

This command is used to read the voltage effective value.

Command syntax:

```
MEASure[:SCALar]:VOLTage:RMS?
```

```
FETCh[:SCALar]:VOLTage:RMS?
```

Returned value:

```
<NR3>
```

MEASure:VOLTage:MAXimum?

FETCh:VOLTage:MAXimum?

This command is used to read the maximum voltage value.

Command syntax:

```
MEASure[:SCALar]:VOLTage:[AMPLitude:]MAXimum?
```

```
FETCh[:SCALar]:VOLTage:[AMPLitude:]MAXimum?
```

Returned value:

```
<NR3>
```

MEASure:VOLTage:THDistort?

FETCh:VOLTage:THDistort?

This command is used to read the total harmonic distortion of voltage.

Command syntax:

```
MEASure:[SCALar:]VOLTage:THDistort?
```

```
FETCh:[SCALar:]VOLTage:THDistort?
```

Returned value:

```
<NR3>
```

MEASure:ETIMe?

FETCh:ETIMe?

This command is used to read the measurement value of time and the unit is s.

Command syntax:

```
MEASure:[SCALar:]ETIMe?
```

```
FETCh:[SCALar:]ETIMe?
```

Returned value:

```
<NR3>
```

MEASure:TEMPerature?

FETCh:TEMPerature?

This command is used to read the measurement value of temperature.

Command syntax:

```
MEASure[:SCALar]:TEMPerature?
```

```
FETCh[:SCALar]:TEMPerature?
```

Returned value:

```
<NR3>
```

MEASure:CURRent:AMPLitude:HOLD

This command is used to set the update mode of measuring extremum.

- OFF: Update every time.
- ON: Update when a new maximum value displays

Command syntax:

```
MEASure[:SCALar]:CURRent:AMPLitude:HOLD <bool>
```

Parameter:

```
0|1|OFF|ON
```

Reset value:

```
OFF
```

Query Syntax:

```
MEASure[:SCALar]:CURRent:AMPLitude:HOLD?
```

Returned value:

```
0|1
```

MEASure:HARMonic?

This command is used to read all the harmonic data.

The order of returned data is the absolute value of total harmonic, the total harmonic component, the fundamental frequency, and each range is as follows:

- The absolute value of 0-50 times voltage harmonic.
- 0-50 times voltage harmonic component
- 0-50 times harmonic phase angle

Command syntax:

```
MEASure:HARMonic?
```

Parameter:

```
None
```

Returned value:

```
<NR3>,<NR3>.....<NR3>
```

MEASure:VOLTage:HARMonic?

This command is used to read the harmonic amplitude.

Command syntax:

```
MEASure:VOLTage:HARMonic[:AMPLitude]? <FUNDamental|TOTal|ALL or NR1>
```

Parameter:

```
FUNDamental| TOTal | ALL or NR1
```

Returned value:

```
<NR3>
```

MEASure:PHASe:HARMonic?

This command is used to read all the phase of harmonic measurement.

Command syntax:

```
MEASure:PHASe:HARMonic? <ALL or NR1>
```

Parameter:

```
ALL or NR1
```

Returned value:

```
<NR3>
```

MEASure:VOLTage:HARMonic:DISort?

This command is used to read the percentage of each harmonic.

Command syntax:

```
MEASure:VOLTage:HARMONIC:DISort? <TOTAL|ALL|NR1>
```

Parameter:

```
TOTal|ALL or NR1
```

Returned value:

```
<NR3>
```

FETCh:VOLTage:HARMonic?

This command is used to read all the harmonic data.

Command syntax:

```
FETCh:VOLTage:HARMONIC[:AMPLitude]? <FUNDamental|TOTal|ALL or NR1>
```

Parameter:

FUNDamental|TOTal|ALL| or <NR1>

Returned value:

<NR3>

FETCh:PHASe:HARMonic?

This command is used to read all the phase of harmonic measurement

Command syntax:

FETCh:PHASe:HARMonic? <ALL or NR1>

Parameter:

ALL or NR1

Returned value:

<NR3>

FETCh:VOLTage:HARMonic:DISort?

This command is used to read the percentage of each harmonic.

Command syntax:

FETCh:VOLTage:HARMonic:DISort? <TOTal|ALL or NR1>

Parameter:

TOTal|ALL or NR1

Returned value:

<NR3>

FETCh:HARMonic?

This command is used to read all the harmonic data.

The order of returned data is the absolute value of total harmonic, the total harmonic component, the fundamental frequency, and each range is as follows:

- The absolute value of 0-50 times voltage harmonic.
- 0-50 times voltage harmonic component
- 0-50 times harmonic phase angle

Command syntax:

FETCh:HARMonic?

Returned value:

<NR3>,<NR3>.....<NR3>

Chapter3 Load Commands

INPut

This command indicates whether electronic load is enabled.

Command syntax:

```
[SOURce:]INPut[:STATe] <bool>
```

Parameter:

```
0|1|OFF|ON
```

Reset value:

```
0
```

Query Syntax:

```
[SOURce:]INPut[:STATe]?
```

Returned value:

```
0|1
```

INPut:REAL?

This command indicates whether the electronic load is really applied to the loop.

Command syntax:

```
[SOURce:]INPut:REAL[:STATe]?
```

Returned value:

```
0|1
```

FUNction

This command is used to read the operating mode of electronic load.

Command syntax:

```
[SOURce:]FUNction <CURRent|RESistance|VOLTage|POWER|SHORT >
```

Parameter:

```
CURRent|RESistance|VOLTage|POWer|SHORT
```

Reset value:

CURRent

Query Syntax:

[SOURce:]FUNctIon?

Returned value:

CURRent|RESistance|VOLTage|POWER|SHORT

INPut:SHORT

This command indicates whether the short simulation is enabled. The user must enable the short function before using this command.

Command syntax:

[SOURce:]INPut:SHORT <bool>

Parameter:

0|1|OFF|ON

Reset value:

0

Query Syntax:

[SOURce:]INPut:SHORT?

Returned value:

0|1

INPut:SHORT:FUNctIon

This command is used to enable or disable the short function.

Command syntax:

[SOURce:]INPut:SHORT:FUNctIon[:STATe] <bool>

Parameter:

0|1|OFF|ON

Reset value:

0

Query Syntax:

[SOURce:]INPut:SHORt:FUNcTion[:STATe]?

Returned value:

0|1

[SOURce:]PROTection:CLEar

This command is used to read the protection state when electronic load is reset.

Command syntax:

[SOURce:]PROTection:CLEar

Parameter:

None

PROTection:AUTO:CLEar

This command is used to set the state when electronic load clear the protection automatically.

Command syntax:

[SOURce:]PROTection:AUTO:CLEar[:STATe] <bool>

Parameter:

<0|1|OFF|ON>

Reset value:

0

Query Syntax:

[SOURce:]PROTection:AUTO:CLEar[:STATe]?

Returned value:

0|1

[SOURce:]LOOP:MODE <CC|CR>

This command is used to set the internal loop state of load.

Command syntax:

```
[SOURce:]LOOP:MODE <CC|CR>
```

Parameter:

```
CC|CR
```

Reset value:

```
CC
```

Query Syntax:

```
LOOP:MODE?
```

Returned value:

```
CC|CR
```

CURRent

This command is used to set the current value of electronic load.

Command syntax:

```
[SOURce:]CURRent[:LEVel][:IMMediate][:AMPLitude] <NRf+>
```

Parameter:

```
MINimum|MAXimum|DEFault or NRf
```

Reset value:

```
MINimum
```

Unit:

```
A
```

Query Syntax:

```
[SOURce:]CURRent[:LEVel][:IMMediate][:AMPLitude]? [MINimum|MAXimum]
```

Returned value:

```
NR3
```

[SOURce:]CURRent:LIMit[:LEVel][:CV]

This command is used to set the maximum current value in CV mode.



This command applies only to IT8615 and IT8615L electronic loads.

Command syntax

[SOURce:]CURRent:LIMit[:LEVel][:CV]

Parameter:

MINimum|MAXimum|DEFault or NRf

Unit

A

Reset value:

MAXimum

Query Syntax:

[SOURce:]CURRent:LIMit[:LEVel][:CV]? [MINimum|MAXimum]

Returned value

<NR3>

CURRent:PROTection

This command is used to set software overcurrent protection level of electronic load.

Command syntax:

[SOURce:]CURRent:PROTection[:LEVel] <NRf+>

Parameter:

MINimum|MAXimum|DEFault or NRf

Unit:

A

Reset value:

MAXimum

Query Syntax:

[SOURce:]CURRent:PROTection[:LEVel]? [MINimum|MAXimum]

Returned value:

<NR3>

CURRent:PEAK:PROTection

This command is used to set the load peak level of software overcurrent protection.

Command syntax:

```
[SOURce:]CURRent:PEAK:PROTection[:LEVel] <NRf+>
```

Parameter:

MINimum|MAXimum|DEFault or NRf

Reset value:

MAXimum

Query Syntax:

```
[SOURce:]CURRent:PEAK:PROTection[:LEVel]? [MINimum|MAXimum]
```

Returned value:

<NR3>

CURRent:PROTection:DELay

This command is used to set the load delay time of software overcurrent protection.

Command syntax:

```
[SOURce:]CURRent:PROTection:DELay <NRf+>
```

Parameter:

MINimum|MAXimum|DEFault or NRf

Unit:

s

Reset value:

MAXimum

Query Syntax:

```
[SOURce:]CURRent:PROTection:DELay? [MINimum|MAXimum]
```

Returned value:

NR3

CURRent:PROTection:STATe

This command is used to enable or disable the overcurrent protection of electronic load.

Command syntax:

```
[SOURce:]CURRent:PROTection:STATe <bool>
```

Parameter:

```
0|1|OFF|ON
```

Query Syntax:

```
[SOURce:]CURRent:PROTection:STATe?
```

Returned value:

```
0|1
```

POWer

This command is used to read power value of Watts as a unit.

Command syntax:

```
[SOURce:]POWer[:LEVel][:IMMEDIATE][:AMPLitude] <NRf+>
```

Parameter:

```
MINimum|MAXimum|DEFault or NRf
```

Unit:

```
w
```

Reset value:

```
MINimum
```

Query Syntax:

```
[SOURce:]POWer[:LEVel][:IMMEDIATE][:AMPLitude]? [MINimum|MAXimum]
```

Returned value:

```
<NR3>
```

[SOURce:]POWer:MAXimum[:LEVel]

This command is used to set the maximum power value.

Command syntax:

[SOURce:]POWer:MAXimum[:LEVel]

Parameter:

MINimum|MAXimum|DEFault or NRf

Unit

W

Reset value

MAXimum

Query Syntax:

[SOURce:]POWer:MAXimum[:LEVel]? [MINimum|MAXimum]

Returned value:

NR3

POWer:PROTection

This command is used to set the power protection level of electronic load.

Command syntax:

[SOURce:]POWer:PROTection[:LEVel] <NRf+>

Parameter:

MINimum|MAXimum|DEFault or NRf

Unit:

w

Reset value:

MAXimum

Query Syntax:

[SOURce:]POWer:PROTection[:LEVel]? [MINimum|MAXimum]

Returned value:

NR3

POWer:PROTection:DELAy

This command is used to set power protection delay of electronic load.

Command syntax:

```
[SOURce:]POWer:PROTection:DELay <NRf+>
```

Parameter:

```
MINimum|MAXimum|DEF or NR3
```

Unit:

```
s
```

Reset value:

```
MAXimum
```

Query Syntax:

```
[SOURce:]POWer:PROTection:DELay? [MINimum|MAXimum]
```

Returned value:

```
<NR3>
```

POWer:PROTection:STATe

This command is used to set power protection of electronic load.

Command syntax:

```
[SOURce:]POWer:PROTection:STATe <bool>
```

Parameter:

```
0|1|OFF|ON
```

Reset value:

```
0
```

Query Syntax:

```
[SOURce:]POWer:PROTection:STATe?
```

Returned value:

```
0|1
```

RESistance

This command is used to set the resistance of electronic load.

Command syntax:

```
[SOURce:]RESistance[:LEVel][:IMMediate][:AMPLitude] <NRf+>
```

Parameter:

MINimum|MAXimum|DEFault or NRf

Unit:

Ohm

Reset value:

MAXimum

Query Syntax:

[SOURce:]RESistance[:LEVel][:IMMEDIATE][:AMPLitude]?
[MINimum|MAXimum]

Returned value:

<NR3>

VOLTage

This command is used to set the voltage level of electronic load.

Command syntax:

[SOURce:]VOLTage[:LEVel][:IMMEDIATE][:AMPLitude] <NRF+>

Parameter:

MINimum|MAXimum|DEFault or NRf

Unit:

V

Reset value:

MAXimum

Query Syntax:

[SOURce:]VOLTage[:LEVel][:IMMEDIATE][:AMPLitude]? [MINimum|MAXimum]

Returned value:

NR3

CFACtor

This command is used to set the CF value of electronic load.

Command syntax:

[SOURce:]CFACtor[:LEVel][:IMMediate][:AMPLitude] <NRf+>

Parameter:

MINimum|MAXimum|DEFault or NRf

Unit:

None

Reset value:

MINimum

Query Syntax:

[SOURce:]CFACtor[:LEVel][:IMMediate][:AMPLitude]? [MINimum|MAXimum]

Returned value:

<NR3>

PFACtor

This command is used to set the PF value of electronic load.

Command syntax:

[SOURce:]PFACtor[:LEVel][:IMMediate][:AMPLitude] <NRf+>

Parameter:

MINimum|MAXimum|DEFault or NRf

Unit:

None

Reset value:

MAXimum

Query Syntax:

[SOURce:]PFACtor[:LEVel][:IMMediate][:AMPLitude]? [MINimum|MAXimum]

Returned value:

NR3

INPut:TIMer

This command is used to set the timer mode.

Command syntax:

```
[SOURce:]INPut:TIMer[:STATe] <bool>
```

Parameter:

```
0|1|OFF|ON
```

Reset value:

```
0
```

Query Syntax:

```
[SOURce:]INPut:TIMer[:STATe]?
```

Returned value:

```
0|1
```

INPut:TIMer:DELay

This command is used to set the delay time of timer.

Command syntax:

```
[SOURce:]INPut:TIMer:DELay <NRf+>
```

Parameter:

```
MINimum|MAXimum|DEFault or NRf
```

Unit:

```
S
```

Reset value:

```
MINimum
```

Query Syntax:

```
[SOURce:]INPut:TIMer:DELay? [MINimum|MAXimum]
```

Returned value:

```
<NR3>
```

MEASure:TYPE

This command is used to set the measurement type of electronic load.

Command syntax:

```
[SOURce:][INPut:]MEASure:TYPE
```

Parameter:

METer|HARMonic|SCOPE

Reset value:

METer

Query Syntax:

[SOURce:][INPut:]MEASure:TYPE?

Returned value:

METer|HARMonic|SCOPE

RATE:DCCV

This command is used to set the load rate in CV mode under DC working mode.

Command syntax:

[SOURce:]RATE:DCCV <SLOW|HIGH>

Parameter:

SLOW|HIGH

Reset value:

SLOW

Query Syntax:

[SOURce:]RATE:DCCV?

Returned value:

SLOW|HIGH

RATE:CC

This command is used to set the load rate in CC mode under AC/DC working mode.

Command syntax:

[SOURce:]RATE:CC <SLOW|HIGH>

Parameter:

SLOW|HIGH

Query Syntax:

[SOURce:]RATE:CC?

Returned value:

SLOW|HIGH

WAVE:TRIGger:VOLTage[:LEVel]

This command is used to set the voltage trigger level.

Command syntax:

WAVE:TRIGger:VOLTage[:LEVel]

Parameter

<NRf>

Unit

V

Query Syntax:

WAVE:TRIGger:VOLTage[:LEVel]?

Returned value:

NR3

WAVE:TRIGger:CURRent[:LEVel]

This command is used to set the current trigger level.

Command syntax:

WAVE:TRIGger:CURRent[:LEVel]

Parameter

<NRf>

Unit

A

Query Syntax:

WAVE:TRIGger:CURRent[:LEVel]?

Returned value:

NR3

WAVE:TRIGger:SOURce

This command can set or read the device taking which kind waveform as trigger source.

Command syntax:

```
WAVE:TRIGger:SOURce <VOLTage|CURRent>
```

Parameter:

```
VOLTage|CURRent
```

Query Syntax:

```
WAVE:TRIGger:SOURce?
```

Returned value:

```
VOLTage|CURRent
```

WAVE:TRIGger:SLOPe

This command is used to set trigger slope when takes waveform as trigger source.

Command syntax:

```
WAVE:TRIGger:SLOPe <POSitive|NEGative|ANY>
```

Parameter:

```
POSitive|NEGative|ANY
```

Query Syntax:

```
WAVE:TRIGger:SLOPe?
```

Returned value:

```
POSitive|NEGative|ANY
```

WAVE:TRIGger:MODE

This command is used to set the trigger mode when take waveform as trigger source.

Command syntax:

```
WAVE:TRIGger:MODE <AUTO|NORMal>
```

Parameter:

AUTO|NORMal

Query Syntax:

WAVE:TRIGger:MODE?

Returned value:

AUTO|NORMal

WAVE:TRIGger:DELay:TIME

This time is used to set the trigger delay time when take a waveform as trigger source. (Note: the delay time setting should be less than the time width of the whole screen.

Command syntax:

WAVE:TRIGger:DELay:TIME <NRf>

Parameter:

<NRf>

Unit:

s

Reset value:

0.0

Query Syntax:

WAVE:TRIGger:DELay:TIME?

Returned value:

<NR3>

WAVE:TRIGger:DIVTime

This command is used to set or read the time/grid value of the waveform display.

Command syntax:

WAVE:TRIGger:DIVTime

Parameter:

0.0005|0.001|0.002|0.005|0.01|0.02|0.05|0.1|0.2

Unit:

s

Query Syntax:

WAVE:TRIGger:DIVTime?

Returned value:

<NR3>

WAVE:RUN

This command is used to start waveform capture.

Command syntax:

WAVE:RUN

Parameter:

None

Query Syntax:

None

WAVE:STOP

This command can stop the waveform capture.

Command syntax:

WAVE:STOP

Parameter:

None

Query Syntax:

None

WAVE:SINGLE

This command is used to trigger a single waveform capture.

Command syntax:

WAVE:SINGLE

Parameter:

None

Query Syntax:

None

WAVE:VOLTage:DATA?

This command is used to obtain the voltage data after normalization.

Command syntax:

WAVE:VOLTage:DATA?

Parameter:

<n>

Query Syntax:

WAVE:VOLTage:DATA?

Returned value:

NR1, NR1...NRf, NRf

WAVE:CURRent:DATA?

This command is used to obtain the current data after normalization.

Command syntax:

WAVE:CURRent:DATA[:NORMalization]?

Parameter:

<n>

Query Syntax:

WAVE:CURRent:DATA[:NORMalization]?

Returned value:

NR1, NR1...NRf, NRf

WAVE:TRIGger?

This command is used to query the trigger status.

Command syntax:

WAVE:TRIGger[:STATe]?

Returned value:

Auto| Auto?|Trig|Trig?|Stop

WAVE:SCOPE:SELECTION

This command is used to set waveform display options.

Command syntax:

WAVE:SCOPE:SELECTION

Parameter:

U|A|UA

Query syntax:

WAVE:SCOPE:SELECTION?

Return value:

U|A|UA

WAVE:KNOB:SELECTION

This command is used to set the knob options.

Command syntax:

WAVE:KNOB:SELECTION

Parameter:

UR|AR|UB|AB|TL|TD|T/d

Query syntax:

WAVE:KNOB:SELECTION?

Returned value:

UR|AR|UB|AB|TL|TD|T/d

WAVE:VOLTage:BASE

This command is used to set the voltage reference.

Command syntax:

WAVE:VOLTage:BASE

Parameter:

<NRf>

Unit:

V

Query Syntax:

WAVE:VOLTage:BASE?

Returned value:

NR3

WAVE:VOLTage:RANGe

This command is used to set the voltage range.

Command syntax

WAVE:VOLTage:RANGe

Parameter:

NR3

Query Syntax:

WAVE:VOLTage:RANGe?

Returned value

<NR3>

WAVE:CURREnt:BASE

This command is used to set the current reference.

Command syntax:

WAVE:CURREnt:BASE <NRf>

Parameter:

NRf

Unit:

A

Reset value:

0.0

Query Syntax:

WAVE:CURRent:BASE?

Returned value:

<NR3>

WAVE:CURRent:RANGe

This command is used to set the current range.

Command syntax:

WAVE:CURRent:RANGe

Parameter:

NR3

Unit

A

Query Syntax:

WAVE:CURRent:RANGe?

Returned value

<NR3>

PORT:OUTPut

This command is used to set the output state of external programmable terminal.

Command syntax:

PORT:OUTPut[:STATe] <bool>

Parameter:

<0|1|OFF|ON>

Query Syntax:

PORT:OUTPut[:STATe]?

Returned value:

0|1

AVERAge:COUNT

This command is used to set the average count of functions.

Command syntax:

AVERAge:COUNT <NR1>

Parameter:

<1-16>

Query Syntax:

AVERAge:COUNT?

Returned value:

NR1

PARAllel:SETUp:SElect

The command selects the phase when the present parameter is set.

Command syntax:

PARAllel:SETUp:SElect <A|B|C|ABC>

Parameter:

A|B|C|ABC

Example:

Par:set:sel A

Query Syntax:

PARAllel:SETUp:SElect?

Returned value:

A|B|C|ABC

PARAllel:VIEW:SElect

This command is used to select the phase of the present measurement display.

Command syntax:

PARAllel:VIEW:SElect <A|B|C>

Parameter:

A|B|C

Example:

Par:view:sel B

Query Syntax:

PARAllel:VIEW:SElect?

Returned value:

A|B|C

PARAllel:BALance[:STATe]

This command sets whether the device is balanced during three phases.

Command syntax:

PARAllel:BALance[:STATe] <0|1|ON|OFF>

Parameter:

<0|1|OFF|ON>

Example:

Par:bal 1

Query Syntax:

PARAllel:BALance[:STATe]?

Returned value:

0|1

Chapter4 System Commands

SYSTem:MODE

This command is used to set the load mode.

Command syntax:

```
SYSTem:[SETup:]MODE <AC|DC>
```

Parameter:

```
AC|DC
```

Reset value:

```
AC
```

Query Syntax:

```
SYSTem:[SETup:]MODE?
```

Returned value:

```
AC|DC
```

SYSTem:CFPF:MODE

This command is used to set the CF/PF/BOTH mode.

Command syntax:

```
SYSTem:[SETup:]CFPF:MODE <CF|PF|BOTH>
```

Parameter:

```
CF|PF|BOTH
```

Query Syntax:

```
SYSTem:[SETup:]CFPF:MODE?
```

Returned value:

```
CF|PF|BOTH
```

SYSTem:CFPF:PRIORity

This command is used to set the priority of CF and PF.

Command syntax:

```
SYSTem:[SETup:]CFPF:PRIOrity <CF|PF>
```

Parameter:

```
CF|PF
```

Query Syntax:

```
SYSTem:[SETup:]CFPF:PRIOrity?
```

Returned value:

```
CF|PF
```

SYSTem:HARMonic:FORMula

This command is used to set the harmonic formula.

Command syntax:

```
SYSTem[:SETup]:HARMonic:[THDistort:]FORMula <THDF|THDR>
```

Parameter:

```
THDF|THDR
```

Query Syntax:

```
SYSTem[:SETup]:HARMonic:[THDistort:]FORMula?
```

Returned value:

```
THDF| THDR
```

SYSTem:COMMunicate:GPIB:ADDRess

This command is used to set GPIB address of electronic load.

Command syntax:

```
SYSTem:COMMunicate:GPIB[:SELF]:ADDRess <NR1>
```

Parameter:

```
NR1
```

Parameter range:

```
0 to 30
```

Reset value:

```
15
```

Query Syntax:

SYSTem:COMMunicate:GPIB[:SELF]:ADDRess?

Returned value:

NR1

SYSTem:COMMunicate:LAN:CURRent:ADDRess

This command is used to set the load IP.

Command syntax:

SYSTem:COMMunicate:LAN:CURRent:ADDRess <STR>

Parameter:

<STR>

Unit:

None

Reset value:

192.168.0.211

Query Syntax:

SYSTem:COMMunicate:LAN:CURRent:ADDRess?

Returned value:

<STR>

SYSTem:COMMunicate:LAN:CURRent:DGATeway

This command is used to set the load gateway.

Command syntax:

SYSTem:COMMunicate:LAN:CURRent:DGATeway

Parameter:

<STR>

Unit:

None

Reset value:

192.168.0.1

Query Syntax:

SYSTem:COMMunicate:LAN:CURRent:DGATeway?

Returned value:

<STR>

SYSTem:COMMunicate:LAN:CURRent:SMASK

This command is used to set the load subnet mask.

Command syntax:

SYSTem:COMMunicate:LAN:CURRent:SMASK

Parameter:

<STR>

Unit:

None

Reset value:

255.255.255.0

Query Syntax:

SYSTem:COMMunicate:LAN:CURRent:SMASK?

Returned value:

<STR>

SYSTem:COMMunicate:LAN:DHCP

This command is used to determine whether set up the dynamic IP address.

Command syntax:

SYSTem:COMMunicate:LAN:DHCP[:STATe] <bool>

Parameter:

0|1|OFF|ON

Query Syntax:

SYSTem:COMMunicate:LAN:DHCP[:STATe]?

Returned value:

0|1

SYSTem:COMMunicate:LAN:SOCKetport

This command is used to set the network communication port.

Command syntax:

SYSTem:COMMunicate:LAN:SOCKetport

Parameter:

<NR1>

Unit:

None

Reset value:

30000

Query Syntax:

SYSTem:COMMunicate:LAN:SOCKetport?

Returned value:

<NR1>

SYSTem:COMMunicate:LAN:MACaddress?

This command is used to return the communication MAC address.

Command syntax:

SYSTem:COMMunicate:LAN:MACaddress?

Parameter:

<STR>

Unit:

None

Query Syntax:

SYSTem:COMMunicate:LAN:MACaddress?

Returned value:

<STR>

SYSTem:BEEPer:IMMediate

This command is used to test the beeper. The AC load will beep for once after executing this command.

Command syntax:

```
SYSTem:BEEPer:IMMediate
```

Parameter:

None

Query Syntax:

None

SYSTem:BEEPer

This command is used to turn on or turn off the beeper. When the parameter is set to 1|ON, the beeper turns on, or the beeper turns off.

Command syntax:

```
SYSTem:BEEPer[:STATe] <bool>
```

Parameter:

0|OFF|1|ON

Query Syntax:

```
SYSTem:BEEPer[:STATe]?
```

Returned value:

0|1

SYSTem:VERSion?

This command is used to query the device version. Return value is a character string as like."YYYY.V".YYYY represents the year and V means the version of that year.

Command syntax:

```
SYSTem:VERSion?
```

Parameter:

None

Returned value:

<NR2>

SYSTem:ERRor?

This command is used to query the error information.

Command syntax:

SYSTem:ERRor?

Parameter:

None

SYSTem:REMOte

This command is used to switch the AC load to remote control mode. In this mode, except Local button (pressing Local button to back to local mode), other keys are locked.

Command syntax:

SYSTem:REMOte

Parameter:

None

Query Syntax:

None

SYSTem:LOCAl

This command is used to switch the AC load to local operation mode. After this command is executed, all the keys on the panel are available.

Command syntax:

SYSTem:LOCAl

Parameter:

None

Query Syntax:

None

SYSTem:RWLock

This command is used to set AC load to remote control mode via RS232 communication interface. And Local button is not available. After this command is executed, set the mode of AC load to remote.control mode. But unlike SYST:REM command, all the keys on the front panel including Local key will be locked.

Command syntax:

SYSTem:RWLock

Parameter:

None

Returned value:

None

SYSTem:BACKlight:BRIGhtness

This command is used to set the brightness of backlight.

Command syntax:

SYSTem:BACKlight:BRIGhtness <NR1>

Parameter:

NR1

Parameter range:

1 to 9

Query Syntax:

SYSTem:BACKlight:BRIGhtness?

Returned value:

<NR1>

Chapter5 Status Commands

STATus:QUEStionable?

This command is used to read the value of Questionable Event register. Electronic load will return a decimal number which is the binary weighted sum of each bits of register. All these bits value is latched and will be cleared after executing this command.

Query Syntax:

STATus:QUEStionable[:EVENT]?

Parameter:

None

Returned value:

<NR1>

Relevant Command:

STATus:QUEStionable:ENABle

STATus:QUEStionable:CONDition?

This command is used to read the value of query condition register to get the AC load's status, such as ocpeak/ocrms/ov/op/ot.

Query Syntax:

STATus:QUEStionable:CONDition?

Parameter:

None

Returned value:

<NR1>

STATus:QUEStionable:ENABle

This command sets or reads the value of the Questionable Enable register and the AC load will return back a decimal value which is a binary weighted sum of all bits from the enable register.

Command syntax:

STATus:QUESTionable:ENABLE <NR1>

Parameter:

0~65535

Power-on value:

Refer to *PSC command

Example:

STATus:QUESTionable:ENABLE 16

Query syntax:

STATus:QUESTionable:ENABLE?

Returned value:

<NR1>

Related command:

*PSC

Bit 0	Frequency questionable
Bit 1/2	Voltage under range
Bit 3	Voltage Over Questionable
Bit 4	Current Peak Over
Bit 5	Current Rms Over
Bit 6	Power Over
Bit 7	temperature
Bit 8	Load Fail

STATus:OPERation?

This query returns the value of the Operation Event register. After this command is executed, the value of the Operation Event register will be cleared.

Query syntax:

STATus:OPERation[:EVENT]?

Parameter:

None

Returned value:

<NR1>

Related command:

STATus:OPERation:ENABLE

The bit configuration of the Operation status registers is as follows:

Bit 0	Calibrating
Bit 5	Trigger

STATus:OPERation:CONDition?

This query returns the value of the Operation Condition register. That is a read-only register, which holds the live (unlatched) operational status of the electronic load.

Query Syntax:

STATus:OPERation:CONDition?

Parameter:

None

Returned value:

<NR1>

STATus:OPERation:ENABLE

This command set the value of the Operational Enable register. This register is a mask for enabling specific bits from the Operation Event register to set the operation summary bit (OPER) of the Status Byte register.

Command syntax:

STATus:OPERation:ENABLE <NR1>

Parameter:

0~65535

Example:

STATus:OPERation:ENABLE 128

Query Syntax:

STATus:OPERation:ENABLE?

Returned value:

<NR1>

Chapter6 Common Commands

*CLS

This command is used to clear following registers:

- Standard Event Register
- Questionable Event Register
- Status Byte Register

Command syntax

*CLS

Parameter

None

*ESE

This command is used to edit the value of standard event enable register. It defines the specified bits from standard event register that will cause the value of ESB bit in status byte register to be 1.

Command syntax

*ESE <NR1>

Parameter

0~255

Power-On Value

Refer to *PSC command

Example

*ESE 128

Query Syntax

*ESE?

Returned value

<NR1>

Relevant Command

*ESR? *PSC *STB?

*ESR?

This command is used to read the value of standard event registers. And values will be cleared to zero after executing this command. The bit definition of standard event register and standard event enable register are the same.

Query Syntax

*ESR?

Parameter

None

Returned value

<NR1>

Relevant Command

*CLS *ESE *ESE? *OPC

*IDN?

This command is used to query related information of AC load.

Query Syntax

*IDN?

Parameter

None

Returned value

<AARD>

Example

ITECH,IT8615,KN34243232,01.00

*OPC

After all other commands executed before *OPC command, the OPC bit in standard event register will be set to 1. Sending query standard event register command will return value 1 into the output buffer.

Command syntax

*OPC

Parameter

None

Query Syntax

*OPC?

Returned value

<NR1>

***RST**

This command reset the device to factory default setup.

Command syntax

*RST

Parameter

None

***SRE**

This command sets the condition of the Status Request Enable Register. After executing this command, AC load will return back a decimal value which is a binary weighted sum of all bits from the enable register.

Command syntax

*SRE <NRf>

Parameter

0~255

Power-on Value

Refer to *PSC command

Example

*SRE 128

Query Syntax

*SRE?

Returned value

<NR1>

Relevant Command

*ESE *ESR? *PSC *STB?

*STB

This command can query the Status Byte register. After executing this command, the bit6 of status byte register will be reset to 0.

Bit Position		6	5	4	3			
Condition		RQS	ESB	MAV	QUES			

The descriptions of Parameter in the table are as follows:

- RQS: request for service
- ESB: Event summary bit
- MAV: Message available
- QUES: One or more questionable event register is reset

Query Syntax

*STB?

Parameter

None

Returned value

<NR1>

Relevant Command

*CLS *ESE *ESR

*SAV

This command stores the present state of the electronic load to a specified location in memory. These parameters including current settings, voltage settings, operation mode and so on.

Command syntax

*SAV <NRf>

Parameter

0~9

*RCL

This command restores the electronic load to a state that was previously stored in memory with a *SAV command to the specified location.

Command syntax

*RCL <NRf>

Parameter

0~9

*TST?

This query causes the electronic load to do a self-test and report any errors.

0 indicates the load passes its self test. Non-zero indicates an error code. In addition, a false information will be generated when the test fails.

Query Syntax:

*TST?

Parameter:

None

Returned value:

<NR1>

Appendix

Description of Questionable Status Bit

Mnemonic	Bit	Value Weight	Bit	Meaning
FE	0	1		Below the frequency range or above the frequency range.
UV	1	2		AC voltage is lower than 45V.
UV	2	4		DC voltage is lower than 7.5V.
OVP	3	8		AC voltage is upper than 350V
OCP	4	16		The peak current value in AC/DC mode is upper than 18A or 45A.
OCP	5	32		The current RMS value in AC/DC mode is upper than 18A.
OPP	6	64		The power value in AC/DC mode is upper than 1800W or 4500W.
OTP	7	128		The temperature value is upper than the limit value.
LDF	8	256		Load Failure.

Description of Operation Status Bit

Mnemonic	Bit	Value Bit Weight	Meaning
CAL	0	1	Calibrating
TRG	5	32	Trigger

Description of Standard Event Status Bit

Mnemonic	Bit	Value Bit Weight	Meaning
OPC	0	1	Operation Complete
QYE	2	4	Query Error
DDE	3	8	Device Error
EXE	4	16	Execution Error. Command parameter is invalid or inconsistent with electronic load, or the command cannot be executed.
CME	5	32	Command Error. Command syntax is incorrect.

Description of Status Byte Bit

Mnemonic	Bit	Value Bit Weight	Meaning
CSUM	2	4	-
QUES	3	8	A questionable enable event has occurred
MAV	4	16	Message Available
ESB	5	32	Event Status Bit
RQS/MSS	6	64	Request for service

Contact US

Thank you for purchasing ITECH products. If you have any doubt about this product, please contact us as follow.

1. Please refer to the CD-ROM of related user's manual in package.
2. Visit ITECH website www.itechate.com .
3. Select the most convenient contact for further consultation.