

PD1550A Series

Advanced Dynamic Power Device Analyzer / Double-Pulse Tester (DPT) for power modules

- Eliminates need to build, test, certify and maintain an in-house system
- VDS / VCE up to 1360 V, ID / IC up to 1000 A
- Characterize 650 V, 1.2 kV, and 1.7 kV-rated power modules
- Accurate VGS high-side characteristics using True Pulse Isolated Probe Technology
- Accurate high current measurement with high-bandwidth RF compensation
- Fast slew rates, high bandwidth measurement probes
- Interface board with solderless contact and exchangeable gate resistor technologies

Achieve repeatable, reliable characterization of wide-bandgap semiconductor power modules



Table of Contents

- Introduction 3
- Dynamic power converter design challenges 9
- Dynamic Power Device Characterization..... 10
- Repeatable, Reliable Measurements..... 12
- PD1550A Overview and Basic Operation 13
- Tested Parameters..... 15

Introduction

Power modules are used in various applications such as electric vehicles (EV) power converters, solar power inverters, trains, home appliances, and aircraft due to ease of design, high energy density and reliability. New, wide-bandgap (WBG) device-based power modules are now used by designers to take advantage of the device's fast-switching operation, reducing the size of the power electronic module and ensuring efficiency. However, WBG power modules also introduce test challenges that require new solutions to properly characterize these devices, while eliminating failed prototypes and reducing design cycles.

Evaluation of power modules is important for power electronics engineers, as well as power module manufacturers, to design efficient, small form factor, and reliable power converters. There are multiple challenges for these engineers to overcome when evaluating power modules, especially for power modules made with WBG devices.

Power Module Test Challenges

High Power Density: Power modules typically have higher power density than discrete power devices, incorporating multiple field-effect transistor (FET) chips to increase current. High current, such as 400 A, is necessary for some EV application where Silicon-Carbide (SiC) devices are being used to increase voltage and to reduce charging time. Therefore, high current with high bandwidth is required for WBG power module testing.

High-Side Device Measurement: Most power electronics applications require half-bridge structures as the basis for inverters and converters. Depending on the application, 2-in-1, 4-in-1, or 6-in-1 power module configurations are used. Two-in-1 configurations are half-bridge structures, 4-in-1 configurations are typically H-bridge structures, and 6-in-1 configurations are used for 3-phase power converters. In the case of discrete power devices, such as in TO-247 packages, it is possible to evaluate an individual device by placing it at the low-side in a DPT test setup. However, it is necessary to perform measurement on both the low-side and the high-side device to characterize a half bridge module. You cannot assume the high-side device behaves exactly as the low-side device. The voltage potential at the junction between the high-side device source and low-side device drain in a half-bridge configuration dynamically changes with large voltage swings as the half bridge is switched. This makes the measurement of the high-side FET very challenging, especially for small gate voltages. Measurement of a 10 V to 20 V gate voltage, while the reference for this measurement (i.e., the source) switches up and down hundreds of volts with fast slew rates is very difficult unless you have high Common Mode Rejection (CMR) probing technology.

Probe Bandwidth and Noise: When measuring high-side V_{gs} , the industry tends to think high CMR is the only necessary parameter to make accurate measurements. However, the bandwidth and noise specifications of the probe are also critical factors for accurate measurement.

No Standard Form Factor: Power modules come in a variety of form factors. Emerging WBG devices drive even more variations because of their high-power density and potential to make the module more compact. When evaluating power modules, the test board layout needs to be carefully designed. DPT boards typically integrate almost all components, such as the connection to the power module, gate drivers, decoupling capacitors, current measurement, etc. The power module is often soldered to the test

board to minimize the stray inductance. However, the need to solder and unsolder the power modules makes evaluation time consuming and inefficient.

Testing at Real World Operating Temperatures: Providing temperature dependence measurements for the power module's dynamic characteristics is critical as the applications often require harsh environments, such as hot deserts, humid tropical forests, or extreme cold with heavy snow fall. Testing power modules in such temperature conditions using a thermostatic chamber is not easy, especially for dynamic characterization.

No Appropriate Solutions Available: Many R&D engineers in the industry either use an older production-type dynamic power module tester for silicon (Si) power devices or a custom set up made in-house by integrating a function generator, power supply, oscilloscope and probes with a custom made DPT board. The former solution provides DPT capability, but is not suitable for detailed evaluation of faster WBG-based devices. And because these systems typically require tedious programming to setup and execute tests, the process can be inefficient and cumbersome. This makes it difficult to apply various test conditions for comprehensive analysis of the power module. The cost to purchase and maintain these production-type systems can also be excessive. The latter solution often lacks repeatable results, ease-of-use, safety, and correlation with the other in-house test systems. The next DPT system design is improved creating different versions of DPT test systems, leading to inconsistent results and additional support and maintenance issues.

Reduce board turns, prototypes, time to market with the PD1550A DPT for Power Modules

As an off-the-shelf measurement solution, the PD1550A delivers repeatable, reliable measurements of WBG semiconductor device-based power modules. The platform also ensures user safety and protection of the system's measurement hardware.

Introduced in 2019, Keysight's PD1500A Power Device Dynamic Analyzer / Double-Pulse Tester, the first complete solution for discreet WBG power device characterization, is now used by power converter designers and power semiconductor manufacturers around the world. The PD1550A expands beyond the PD1500A's capabilities to become the first complete solution to test power modules (up to 1360 V, up to 1000 A). As a result, automotive original equipment manufacturers (OEMs), Tier 1 suppliers, and power converter designers can fully understand power module characteristics to design safe and reliable power circuits for automotive applications.

Some of the key features that solve the challenges for power module testing described in the previous section are discussed below.

High Power Density: Current capacity is increased from 200 A to 1000 A while still using a coaxial shunt as a current sensor to maintain high bandwidth current measurements.



Figure 1. Test results for SiC power module (ID > 500 A)

High-Side Device Measurement: A big challenge to test gate voltage characteristics on the high-side device is solved by newly developed ‘True Pulse Isolated Probe Technology’. Specially designed probing, fully isolated from the other probes, allows accurate Vgs measurement for the high-side device in a half-bridge configuration power module as shown in Figure 2. It clearly shows the newly developed ‘True Pulse Isolated Probe’ has sufficient CMR and superior noise performance (blue waveform) compared to the commercially available optically isolated probe (gold waveform).

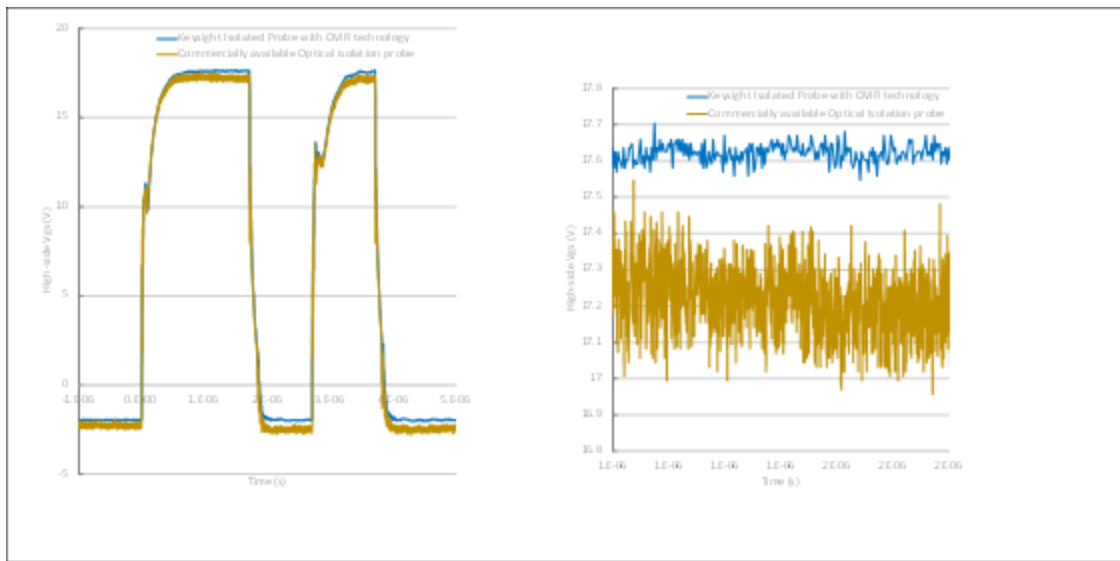

Figure 2. High-side Vgs measurement results comparison

Probe Bandwidth and Noise: Depending on the current level and required accuracy, users can select and attach a 5 mΩ or a 50 mΩ coaxial shunt resistor. Each shunt is characterized to flatten the frequency response to the specified bandwidth. RF compensation data is supplied for each shunt and is applied to the raw measurement data to produce accurate results by eliminating unwanted bandwidth variation of the current shunts. Figure 1 shows example test results for ID > 500 A measured with the new PD1550A. Figure 3 shows the effectiveness of RF compensation, which makes the waveform accurate and consistent regardless of the bandwidth of the shunt resistor which is used.



Figure 3. Effect of RF compensation on drain current

No Standard Form Factor: An interface board that attaches to the power module is the only component required to be customized depending on the power module's layout. Keysight application experts can provide thorough design services to create these customized boards. An example of an interface board is shown in Figure 4. These customized boards incorporate technology that makes it easy to attach the board to the power module without soldering, which allows repeated use of the board for many DUTs, while creating a solder-like connection. The gate resistor (R_g) is an important component when characterizing the power module. Each gate resistor module has an EEPROM which contains the resistor value. The PD1000A control software recognizes the resistor value automatically and uses the value for testing. An EEPROM is also used on other DPT components, such as the interface board and the gate driver board, reducing the chance of having operator error and further enhancing the reliability of the system.



Figure 4. DUT Interface board and gate resistor module

Testing at Real World Operating Temperatures: The PD1550A supports two types of thermal management techniques. One is a hot plate which allows a temperature range from room temperature to 200 °C. The other technique is a ThermoStream® that can make measurements in cold ambient down to -40 °C, as well as high temperatures up to 200 °C. The thermal test equipment is automatically controlled by the system software making it simple to obtain temperature dependent characteristics.

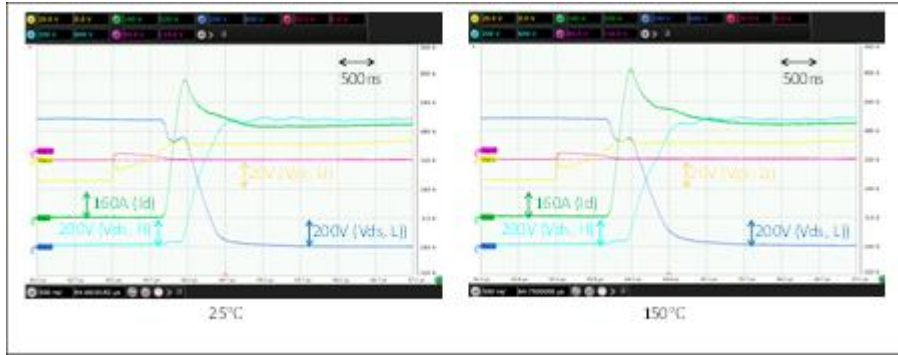

Figure 5. IGBT power module test result examples (25 °C & 150 °C)

No Appropriate Solutions Available: In addition to solving all the challenges presented above, the Keysight PD1550A complies with international safety regulations such as CSA, CE, and KCC. You will be ensured to test your device safely.

Double-Pulse Test Overview: Established and emerging measurement methods

Fully characterizing a SiC-based WBG power module devices requires both static and dynamic measurements. Keysight's B1505A and B1506A power device analyzers excel at static measurements. The PD1500A and new PD1550A have the needed flexibility to address a variety of dynamic measurements and the evolution of JEDEC standards as they take shape for discrete devices and power modules, respectively.

Static measurements: The following parameters are typically used to understand the static characteristics of a power device:

- Output characteristics
- On-resistance
- Threshold voltage
- Transconductance
- Junction, input, output and reverse transfer capacitance
- Breakdown voltage
- Gate charge

Static measurements: Power device analyzers

Keysight is the industry's de facto leader in static measurements, and the preferred solutions are the B1505A and B1506A power device analyzers.

The B1505A provides the broad and deep measurement capabilities needed by developers creating new semiconductor devices. The B1506A provides the core set of test functions more commonly needed by product designers when evaluating semiconductor devices for use in a power module.

www.keysight.com/find/B1505A

www.keysight.com/find/B1506A

Dynamic measurements: As JEDEC continues to define the dynamic testing of WBG devices, some standardized tests are starting to emerge. The DPT determines these key performance parameters:

- Turn-on characteristics
- Dynamic on-resistance
- Switching characteristics
- Gate charge
- Turn-off characteristics
- Dynamic current and voltage
- Reverse recovery
- Derived output characteristics

Ruggedness testing (coming soon to PD1550A): Since WBG devices operate with high voltages and at high temperatures, characterizing ruggedness is necessary. The key measurements determined by short-circuit testing and avalanche testing include:

- Short-circuit conduction time
- Short-circuit energy
- Avalanche energy

Dynamic Power Converter Design Challenges

Semiconductor and power engineering teams are in a tenuous position. The market forces them to quickly develop and ship reliable products, while needing to overcome changing technology, unreliable measurements in a hazardous test environment. In the absence of commercial characterization solutions, most engineering teams have been forced to develop their own solutions. Some of their key challenges are listed below:

- Improving efficiency has resulted in higher frequency switching converters. Accounting for the high-frequency energy is important in both characterizing power semiconductors and in modeling and simulating them in power converter designs. This additional complication challenges the traditional power designer.
- The combination of increased frequency and higher power affects the reliability of the measurements. It is often hard to distinguish whether the measured signal is the device characteristic or the parasitic characteristic of the measurement setup.
- Operating with greater voltage (> 1000 V) and current (> 100 A) levels leads to a more hazardous test environment. Design and test engineers need to use extra precaution when working with lethal power levels.
- The process for making WBG semiconductors is still maturing and is not as well studied as Si-based semiconductors. The resulting unproven reliability makes it difficult for many designers to commit to WBG devices for their designs. This isn't stopping some designers from using these new devices for mission critical applications such as renewable energy and EV's.
- Characterization and test standards are under development and will soon drive a common methodology for testing WBG devices.

As a result of the challenges above, WBG device manufacturers struggle to consistently characterize their devices. Data sheets often provide specifications defined more narrowly than the breadth of a specific application (e.g., temperature). These specifications are often typical and not guaranteed. As a result, power-converter designers often end up characterizing the semiconductors themselves, augmenting the manufacturer's provided specifications. Obviously, new approaches are needed for characterizing, modeling and simulating power semiconductors and their respective converter designs.



JC-70 Wide-Bandgap Power Electronic Conversion Semiconductors

The JEDEC standards recognized the need to provide WBG standards for the power semiconductor industry.

In September of 2017, the JC-70 Wide Bandgap Power Electronic Conversion Semiconductor committee was formed for both GaN JC-70.1 and SiC JC-70.2

Each section has three task groups, focusing on Reliability and Qualification Procedures, Datasheet Elements and Parameters, and Test and Characterization Methods. Keysight actively participates in developing these standards.

DPT Parameters – Low Side

Group	Parameters	Description	Associated Standards
Turn-On Characteristics	$t_{d(on)}$, t_r , t_{on} , $e_{(on)}$, dv/dt , di/dt	Characterizes how quickly the transistor can turn on, the maximum di/dt and dv/dt , and the resulting energy loss. Contributes to switching loss characteristic.	FET – IEC 60747-8 IGBT – 60747-9
Turn-Off Characteristics	$t_{d(off)}$, t_r , t_{off} , $e_{(off)}$, dv/dt , di/dt	Characterizes how quickly the transistor can turn off, the maximum di/dt and dv/dt , and the resulting energy loss. Contributes to switching loss characteristic.	FET – IEC 60747-8 IGBT – 60747-9
Switching Characteristics	I_d vs. t , V_{ds} vs. t , V_{gs} vs. t , I_g vs. t , Clamped V_{ds} vs. t , e vs. t , I_d vs. V_{ds} (switching locus)	These time-based parameters are waveforms retrieved directly from the oscilloscope. The I_d vs. V_{ds} (switching locus) are derived from the waveforms.	
Reverse Recovery	t_{rr} , Q_{rr} , E_{rr} , I_{rr} , I_d vs. t	Characterization of reverse recovery of body diode in vertical FETs. Provides additional timing information regarding how quickly the transistor can switch between on and off.	IEC 60747-8 JESD 24-10
Gate Charge	V_g vs. Q_g , $(Q_{gs(th)}, Q_{gs(pl)}, Q_{gd})$	The voltage and the current of the gate are measured during a double pulse turn-on operation. The charge on the gate during different gate voltage transitions is characterized. This parameter is used to determine the driving loss of the transistor.	JESD 24-10
Derived Output Characteristics	I_d vs. V_g , I_d vs. V_d	Provides basic transfer characteristics for the semiconductor.	

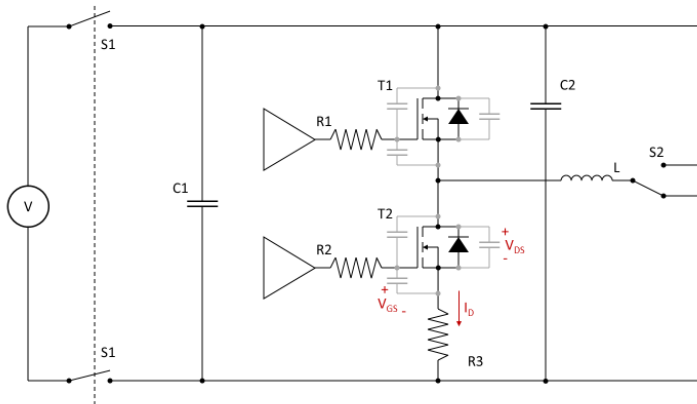

Figure 8. Basic reverse recovery test configuration (T2 body diode – DUT)

Reverse recovery is also measured using a double pulse, but the load inductor is now switched across T2 and T1 is used to charge the inductor. After T1 is turned off, the body diode in T2 conducts. When T1 is turned on again, the reverse recovery of T2 can be measured.

Repeatable, Reliable Measurements

Common Measurement Practice

Keysight's PD1550A uses many common measurement practices. Some attenuation probe errors are eliminated by compensating the passive probes and adjusting the offset of the differential probe as recommended. Care was taken to minimize parasitic capacitance and inductance when laying out the DPT setup in the fixture. In order to correlate the timing of each measurement probe, de-skew is also implemented.

AutoCal

Gain and offset errors for each oscilloscope channel/probe can often lead to errors in the DPT waveforms, which will impact the extracted parameters. The PD1550A incorporates an automatic calibration technique that uses a known-good accurate, internal system voltage standard to measure and characterize each oscilloscope channel. Gain and offset errors are compensated for to provide more accurate and repeatable DPT waveforms.

Current Shunt Compensation

Current shunts can have poor bandwidth and inconsistent performance from shunt to shunt. Keysight characterized a popular coaxial shunt with a network analyzer and found a wide variability in bandwidth, from ~25 MHz to 300 MHz. This variability significantly impacts dynamic testing of higher-speed WBG power devices. Every PD1550A system is supplied with pre-compensated current shunts for ID / IC measurements. The compensation applies the inverse of the shunt's transfer function to the output signal measured in order to flatten the response across the bandwidth of interest. This method increases the accuracy of ID / IC measurements, resulting in a more accurate extraction of DPT parameters.

Safe Test Environment

Your safety is critical when testing power semiconductors. Keysight designed multiple safety features into the PD1550A to enhance your safety. The test environment is inside the test system cabinet, protecting the user from high voltages. When > 42V is present, the doors are locked and the red light is illuminated.

For further protection, the PD1550A provides an Emergency Off Operation (EMO) button to disconnect high voltages when pressed.

Expandable Power Device Platform

The initial PD1550A introduction focuses on performance testing such as DPT for IGBT and SiC power modules. However, the PD1550A platform was developed with modularity in mind, enabling expansion of its capabilities as needs and standards develop.

Planned Future Enhancements

Ruggedness tests (short circuit and avalanche) are planned to be added to the platform in the future. As the JEDEC JC-70 standard evolves, we will continue enhance the suite of characterization tests.

PD1550A Overview and Basic Operation

The PD1550A is designed to be modular, allowing for test on a variety of power modules based on SiC or IGBTs, characterization tests (DPT, reverse recovery, gate charge), and ruggedness tests (short-circuit, avalanche; coming soon), at different power levels. The initial system provides complete DPT characterization and parameter extraction for power modules, supporting maximum power operation at 1.36 kV and 1000 A.

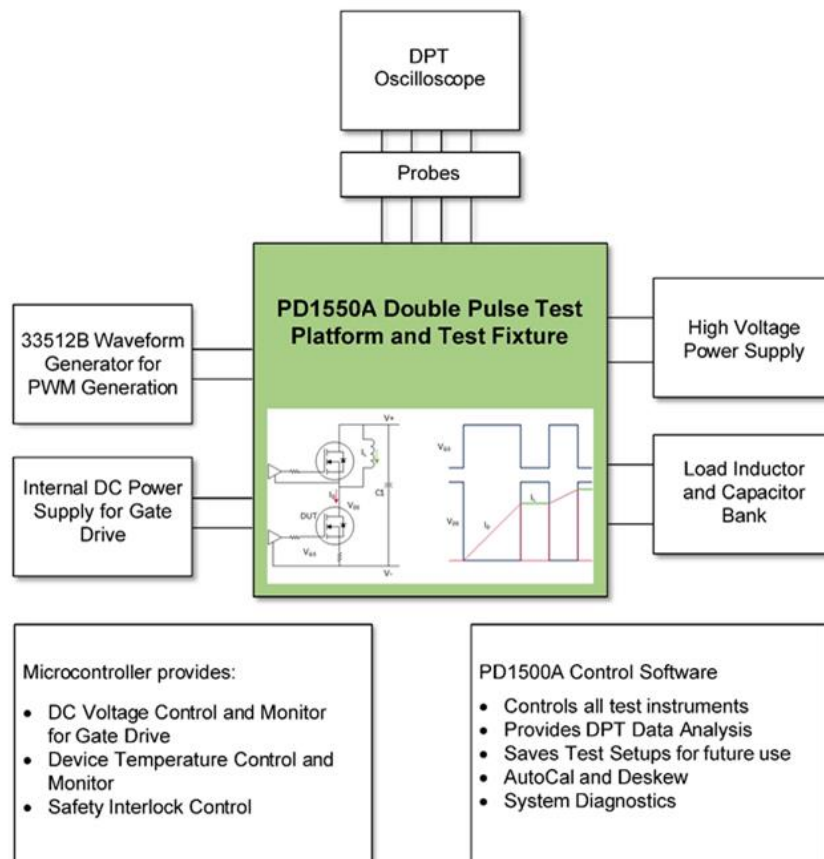

Figure 9. PD1550A block diagram

Module Interface Boards, Fixture

The standard PD1550A interface boards allow for 62 mm or FM3 power module packages to interface with the system. Connections for de-skew and AutoCal are readily available. The system will scale to the appropriate size for the DC-link capacitor and load inductors. If these standard configurations do not meet your needs, Keysight is ready to work directly with you to design an interface board to your exact specifications.

User Configuration, Control and Analysis

The PD1550A is controlled with a simple and flexible graphical user interface. It provides test setup, execution, DPT display and data logging. Both the raw waveform and the extracted parameters are available from the local database. A simple semi-automated sequence is shown below.

1. Connect DUTs onto the appropriate interface board using soldless connection technology
2. Attach hot plate and thermocouple (if used)
3. Connect probes to interface board
4. Set up test parameters in the control software
5. Press "Start"
6. Repeat steps 3 and 4 for reverse recovery diode test or other tests

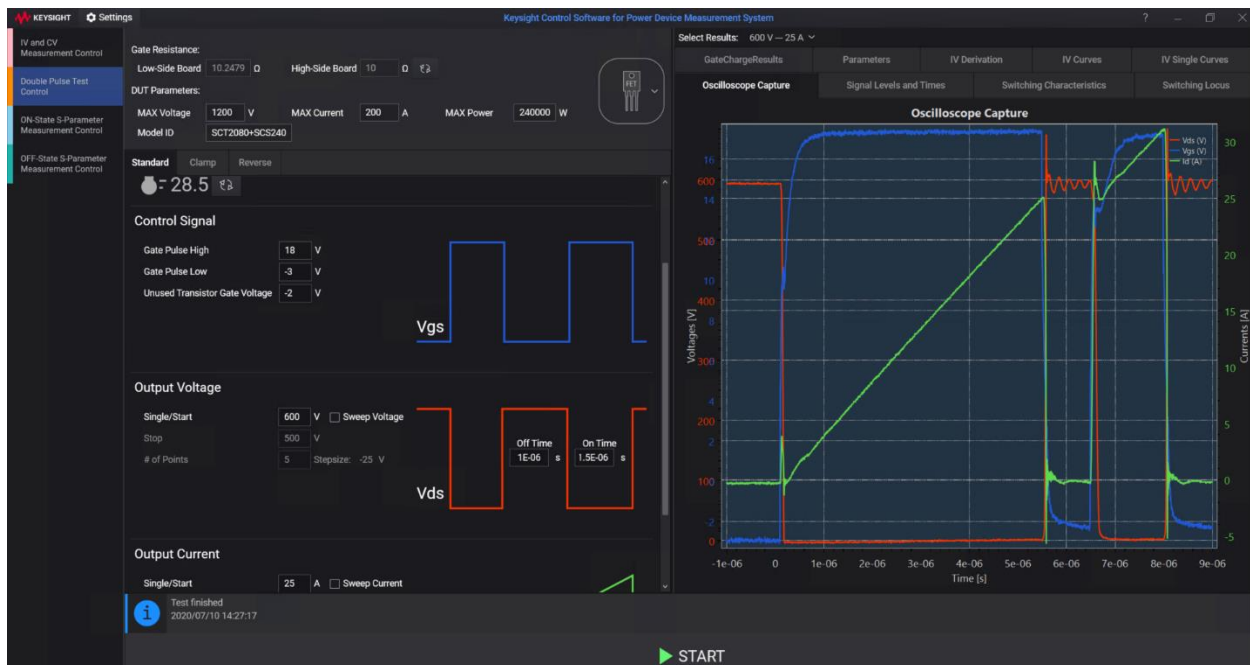

Figure 10. Example PD1550A user interface in PD1000A control software

Tested Parameters^{1,2}

Test	Parameter / Characteristics	Symbol	
Double Pulse Test/Clamp	Turn-on delay time	td(on)	
	Turn-off delay time	td(off)	
	Rise time	tr	
	Fall time	tf	
	Turn-on time	ton	
	Turn-off time	toff	
	Turn-on energy	e(on)	
	Turn-off energy	e(off)	
	di/dt	di/dt	
	dv/dt	dv/dt	
	On-resistance	Rds(on)	
	Switching characteristics	Id vs. t	
		Vds vs. t	
		Vgs vs. t	
		Ig vs. t	
e vs. t			
Switching locus	Id vs Vds ³		
Reverse Recovery	Reverse recovery current rise time	ta	
	Reverse recovery current fall time	tb	
	Reverse recovery time	trr = ta + tb	
	Reverse recovery charge	Qrr	
	Reverse recovery energy	Err	
	Maximum reverse recovery current	Irr	
	Reverse recovery current characteristics	Id vs. t	
Gate Charge ⁴	Total gate charge	Qg	
	Threshold gate charge	Qgs(th)	
	Plateau gate charge	Qgs(pl)	
	Gate drain charge	Qgd	
	Gate charge curve	Vgs vs. t	
Multiple Tests	Derived output characteristics	Id vs. Vd ³	

¹ Based on standards, such as IEC 60747 and JESD24; Other standards methods available in PD1000A software.

² Long off time leads to significant loss of inductor current. This leads to limitations of parameter extraction

³ Quality of the characteristics depends on the cleanliness of measured switching characteristics.

⁴ Gate charge parameter extraction requires gate current monitoring. The quality of gate charge parameters depends on the smoothness of the measured curve. High gate resistance (e.g. ≥ 100 Ohm) is recommended.

Specifications

Category	Type			Item	Specification		
Electrical	General			Sample Rate	16 GSa/s		
				Sampling Accuracy	8 ppb + 75 ppb/year		
				Deskew Accuracy	200 ps (typical)		
	Drain/ Collector Channel	DC	Source	Max Voltage	1360 V ⁵		
				Min Voltage	300 V ⁶		
				Max Current	1000 A ⁷		
				Min Current	50 A ⁸		
				Voltage Programming Resolution	23 mV		
				Measure	Voltage Accuracy	2% of range (typical)	
					Current Accuracy	4% of range (typical)	
		AC	Measure	Voltage probe bandwidth	400 MHz		
				Current shunt bandwidth (compensated)	200 MHz (typical)		
				Voltage transition time	< 10 ns (depends on DUT response, Rg)		
				DC	Source	High Level Max/Min Voltage	28 V / 0 V
						Low Level Max/Min Voltage	0 V / -28 V
						Voltage Resolution	<0.1 V (typical)
		Measure	Max Current	10 A (sink and source)			
	Voltage Accuracy		2% of range (typical)				
	Current Accuracy		4% of range (typical)				
	AC	Source	Timing Resolution / Accuracy	100 ps / 200 ps			
			Typical 1st Pulse Width	10 to 200 μ s			
			Min Pulse Width (1st Pulse)	1 μ s ⁹			
			Max Off-Time between 1st and 2nd Pulse	25 μ s ¹⁰			
			Min Off-Time between 1st and 2nd Pulse	1 μ s ⁹			
			Max Pulse Width (2nd Pulse)	25 μ s ¹¹			
			Min Pulse Width (2nd Pulse)	1 μ s ⁹			
			Measure	Voltage probe bandwidth	200 MHz		
				Current probe bandwidth	200 MHz		

⁵ Maximum supply voltage 1.36 kV; capable of characterizing 650 V, 1.2 kV, and 1.7 kV-rated devices

⁶ This is the minimum voltage; At this voltage the system will reach 1000 A.

⁷ First (1st) pulse – current after 2nd pulse must not exceed 1100 A

⁸ Lower current values result in less accuracy

⁹ Lower values may be possible, but are not recommended nor tested

¹⁰ Large values for off-time lead to significant loss of inductor current. This leads to limitations of parameter extraction

¹¹ Second pulse-width must be selected so that max system current is not exceeded

Category	Type	Item	Specification		
Electrical	Modular Components	Load Inductors (typical)	25, 100, and 600 μ H		
		DC-Link Capacitor (typical)	TBD		
DUT	Power Modules	MOSFET, IGBT			
		Silicon and SiC			
		62 mm modules, custom ¹²			
System	Mechanical	Safety Enclosure	Size – without signal lamp	125 cm (W) x 103 cm (D) x 174 cm (H)	
			Size – with signal lamp	125 cm (W) x 103 cm (D) x 205 cm (H)	
			Weight – complete system	~324 kg	
	Environmental		Operating Temperature	20 °C to 30 °C	
			Operating Humidity	50 % to 70 % RH, non-condensing	
			Operating Altitude	Up to 2000 m	
			Warmup time	1 hour	
			Storage Temperature	0 to 40 °C	
			Line Power	Voltage	200 V to 240 V, \pm 10% 50/60 Hz
	Protection & Safety		Power Consumption (typical)	TBD ¹³	
			Power Consumption (max)	2.7 kW	
			Emergency Off switch (EMO)		
			Oscilloscope protection (Clamp output)	\pm 15 V (typical)	
			Safety Hood	Maximum energy in the system	TBD
				Lock	> 42 V ¹⁴ (typical)
				Open hood detection	High-voltage disconnect; DC-Link capacitor discharged
	Over-temperature Shutdown	> 50 °C (typical)			
Interface	LAN		10/100/1000 Base-T Ethernet		

¹² For custom modules, please contact Keysight

¹³ Without heater/heater-cooler accessory

¹⁴ Safety hood cannot be opened when > 42 V is present in the system

How to Order

How to order your PD1550A Advanced Dynamic Power Device Analyzer/Double Pulse Tester

PD1550A Core System (1 required)

The core PD1550A system is comprised of all the necessary equipment to perform dynamic / double-pulse testing. A list is provided below for reference:

PD1550A Core System

1 x DPT Oscilloscope with accessories
1 x Oscilloscope protection probe
1 x 1.2kV high-voltage power supply with accessories
1 x DPT Function generator with accessories
1 x Auto calibration basic pack
1 x DPT Rack & Safety Enclosure with accessories
1 x Lift Table

Fixture Options (1 required)

Option	Description
MOD	Test Package for Power Modules, 1000 A

DPT Interface Boards Boards (1 required)

Choose the DPT interface boards that match the module(s) under test. Required to mount the DUT to the DPT fixture. For customized interface boards, please contact Keysight.

Option	Description
I01	DPT Interface Board, 62 mm modules
I02	DPT Interface Board, 62 mm modules with decoupling capacitors
I03	DPT Interface Board, FM3 half-bridge modules with decoupling capacitor

Gate Resistor Boards (1 required; 2 per)

Choose at least one gate resistor board (set of 2). Gate resistor boards plug into the gate driver board.

Option	Description
G01	Gate resistor, blank
G02	Gate resistor, 0 Ohm
G03	Gate resistor, 1 Ohm
G04	Gate resistor, 2.2 Ohm
G05	Gate resistor, 4.7 Ohm
G06	Gate resistor, 10 Ohm
G07	Gate resistor, 22 Ohm
G08	Gate resistor, 100 Ohm
G09	Gate resistor, 400 Ohm

Gate Driver Boards (1 required; high and low pair)

Required to drive the gate of the power module.

Option	Description
GD1	Gate Driver Board, ± 28 V

Larger Lift Table (1 optional)

A larger lift table if the lift table included in the Core System is not sufficient for your power module.

Option	Description
LT2	Lift Table, L: 300 mm, B: 150 mm

Software Licenses (PD1020A required)

License	Description
PD1020A	License for Double-Pulse Test Measurement in PD1000A Control Software (required)
PD1021A	License for Offline Analysis of Double-Pulse Test Measurements in PD1000A Control Software (requires D9010BSEO)
D9010BSEO	Infiniium Offline - Base Software (requires PD1021A)

For more information, please go to www.keysight.com/find/PD1550A.

Learn more at: www.keysight.com

For more information on Technologies' products, applications, or services, please contact your local Keysight office. The complete list is available at:

www.keysight.com/find/contactus



This information is subject to change without notice. © Keysight Technologies, 2022, Published in USA, May 5, 2022, 3122-1493.EN