



Signal Studio for Pulse Building N7620B

Features

- Create Keysight Technologies, Inc. validated and performance optimized reference signals for radar and electronic warfare (EW) test
- Basic options produce corrected wideband pulsed signals for component test
- Advanced options produce pulse width patterns with jitter, pulse repetition interval patterns with jitter and wobulation, and antenna scans for receiver test
- Create radar signals with 2 GHz of bandwidth from 1 to 44 GHz RF
- Import custom waveforms to simulate clutter, radar cross section, electronic countermeasures, and radar threats from intelligence database
- Use the COM API for test automation
- Accelerate the signal creation process with a user interface based on parameterized and graphical signal configuration and tree-style navigation

Simplify Radar/EW Test Signal Creation

Keysight Signal Studio software is a flexible suite of signal-creation tools that will reduce the time you spend on signal simulation. For radar/EW, Signal Studio's performance-optimized reference signals—validated by Keysight—enhance the characterization and verification of your devices and systems. Through its application-specific user-interface you'll create custom test signals for component, transmitter, and receiver test.

Component and transmitter test

Signal Studio for pulse building's basic and advanced capabilities allow you to create corrected signals for component and transmitter test. Its user-friendly interface lets you design pulses with modulation, sequence them in pulse repetition intervals, and apply antenna scans and windowing functions. The applications include:

- Parametric test of components, such as amplifiers, mixers, diplexers, circulators and filters
- Tests of transmitter leakage into receiver
- System tests of analog performance in baseband/IF/RF stages
- Bench testing of novel radar waveforms

Receiver test

Signal Studio for pulse building's capabilities enable you to create corrected signals for receiver test applications including:

- Performance verification and functional test of receivers during RF/IF/baseband integration and system verification
- Testing of threat identification for radar warning receivers and jammers
- Bench testing of novel radar waveforms

Apply your signals in real-world testing

- Vector signal generators
 - VXG
 - PSG
 - MXG/EXG
 - ESG
- Arbitrary waveform generators
 - M8190A
 - M9330A/N8241A/N6030A

Component and Transmitter Test

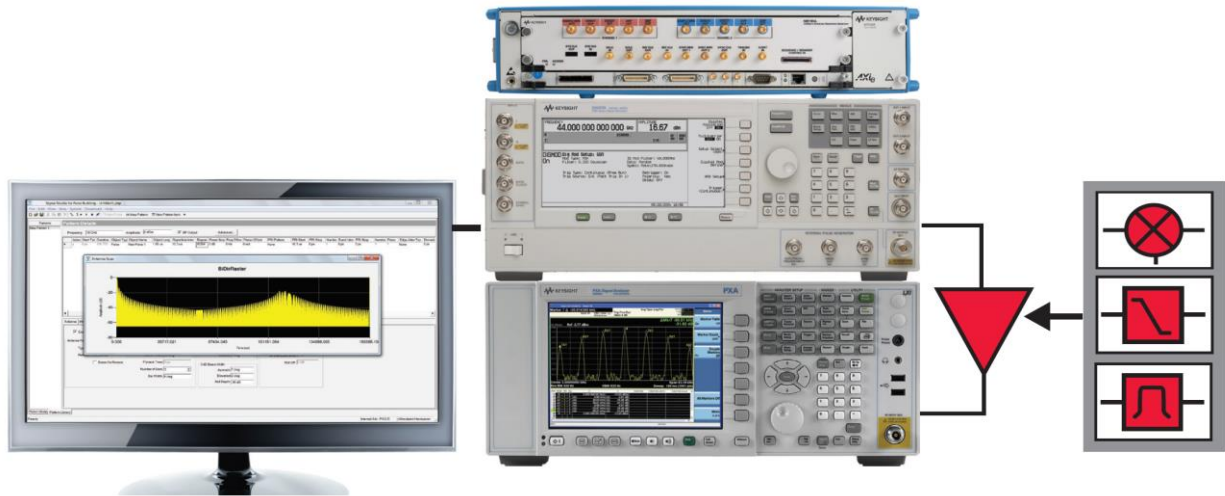

Figure 1. Typical traveling wave tube amplifier (TWTA) test configuration using Signal Studio's basic capabilities with a Keysight signal generator and an X-Series signal analyzer.

With Signal Studio's basic capabilities create and customize radar waveforms to characterize the power and modulation performance of your components and transmitters. As radar modulation bandwidths, frequency diversity, and frequency hopping increase, Signal Studio for pulse building works with Keysight arbitrary waveform generators and signal generators to keep you ahead of radar signal demands. Also, easy manipulation of a variety of signal parameters, including pulse width, rise time, fall time, pulse repetition interval, modulation bandwidth, and modulation type, simplifies transmitter component test.

- Create radar modes at a variety of duty cycles, power levels, and frequencies to test power amplifier linearity, gain, and amplitude flatness
- Add modulation onto pulse to measure chip width, chirp linearity and time side lobe levels
- Use a variety of markers to measure average power, peak power, band power, duty cycle jamming-to-signal ratio, and adjacent channel power on an X-series signal analyzer
- Measure transmitter frequency diversity using list sweep, spectrogram or recording

Receiver Test

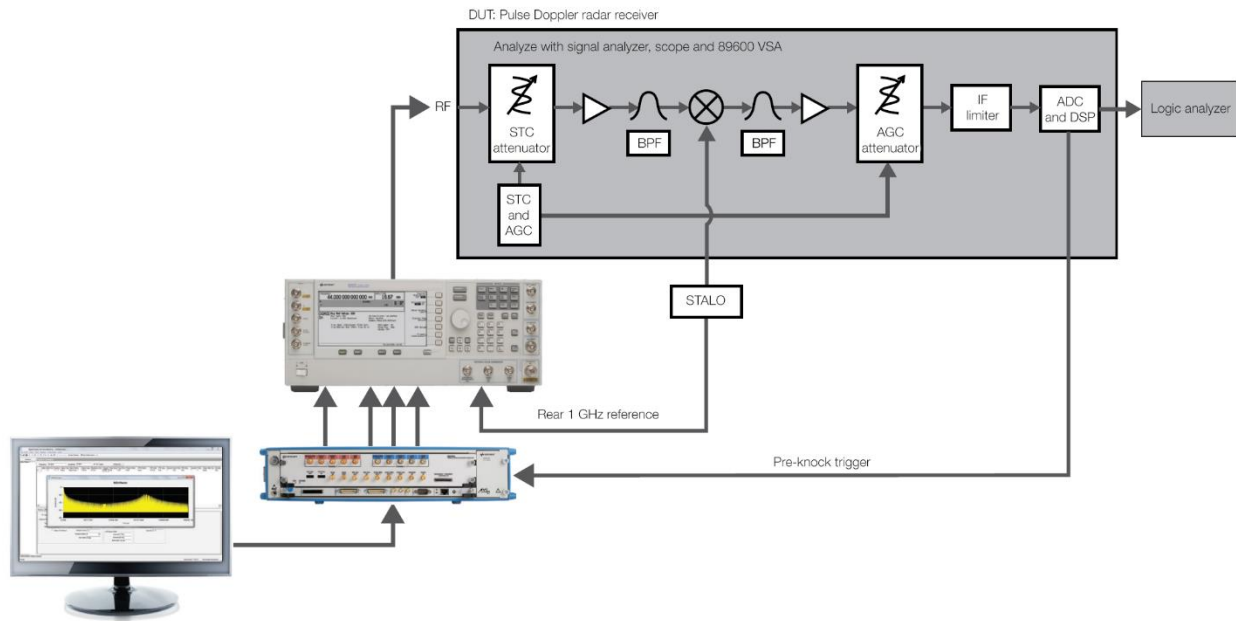

Figure 2. Test your pulse Doppler radar receiver using Signal Studio's advanced capabilities. Achieve coherence and synchronization with a phase reference for the signal generator (with Option H1G) and a trigger for the arbitrary waveform generator. The phase reference can come from the STALO or COHO depending on the receiver architecture. Alternative IF architectures are depicted in dotted lines.

The advanced capabilities of Signal Studio for pulse building make coherent testing of radar receivers easy. Use a variety of signal sources and arbitrary waveform generators to customize your solution for your testing needs. Achieve 2 GHz of modulation bandwidth with phase coherence up to 44 GHz.

Use Keysight's unparalleled signal generation and arbitrary waveform generation technology with Signal Studio for pulse building's advanced capabilities to test electronic warfare receivers and jammers. Emulate any radar threat and future-proof your electronic warfare and electronic countermeasure testing up to 44 GHz.

Radar receiver testing

- Create pulse width patterns with jitter to test response to impairments
- Create pulse repetition interval patterns to test range gating and range/Doppler ambiguity resolution
- Add frequency and phase offsets to test moving target indicator modes and Doppler processing
- Create custom pulses with clutter to test clutter rejection performance
- Import custom waveforms created in MATLAB or SystemVUE to simulate radar cross section, clutter, and electronic countermeasures

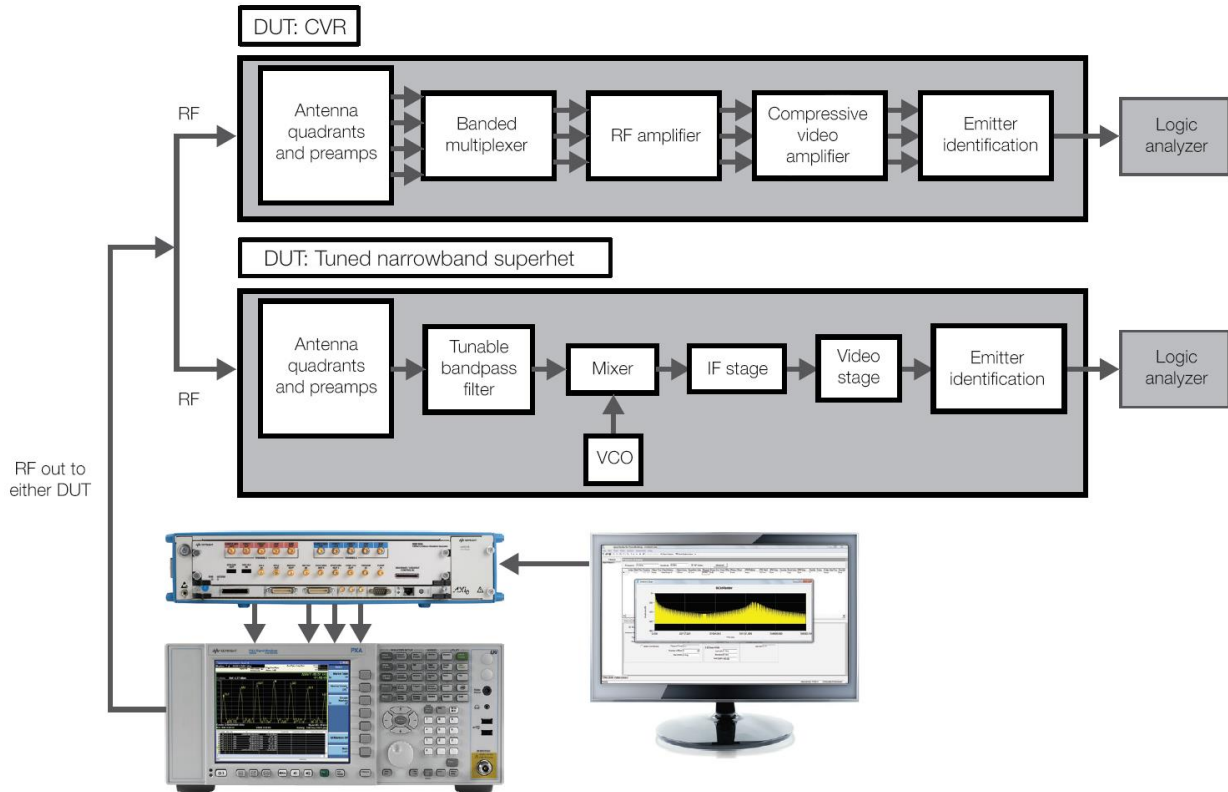

Figure 3. Generate high-fidelity wideband radar signals to test your EW receivers with Keysight signal generators, arbitrary waveform generators and Signal Studio for pulse building's advanced capabilities with 2 different receiver architectures (CVR or tuned narrowband superhet).

RWR/jammer receiver testing

- Define a pulse width, rise and fall time, rise time shape, and modulation-on-pulse
- Add a pulse to a pattern and specify pulse repetition interval patterns or wobble
- Organize nested patterns into coherent processing intervals, looks, and dwells
- Create an antenna scan for more threat emitter realism
- Import data from an emitter intelligence database for rapid EW reprogramming
- Use a logic analyzer to verify pulse descriptor words, pulse de-interleaving, emitter identification, input scheduling, and interface management

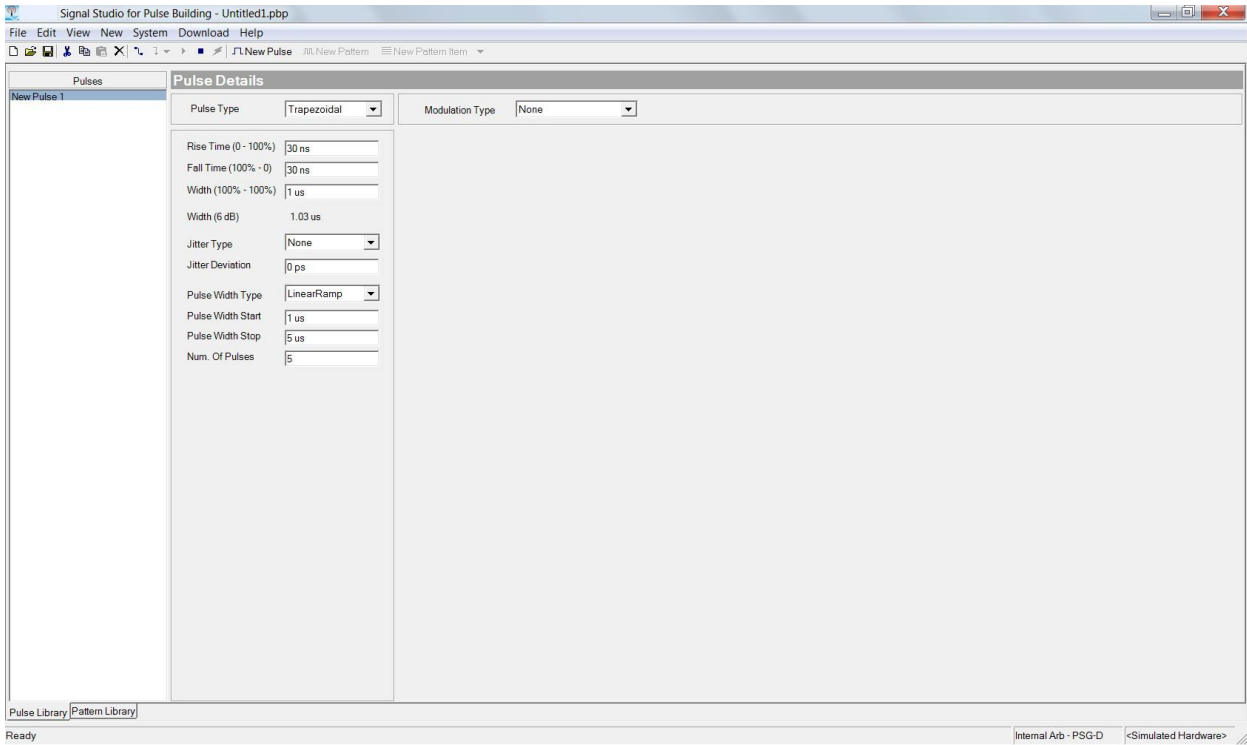

Figure 4. Create a custom pulse library.

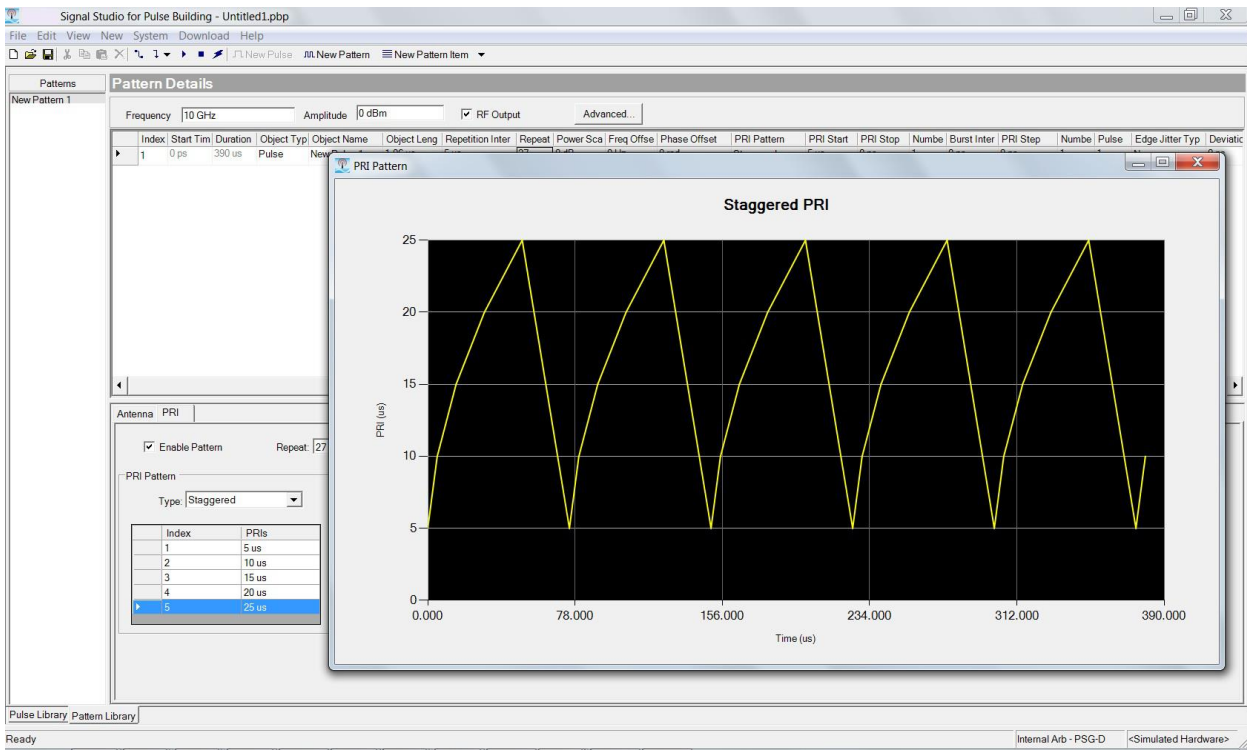

Figure 5. PRI pattern - staggered.

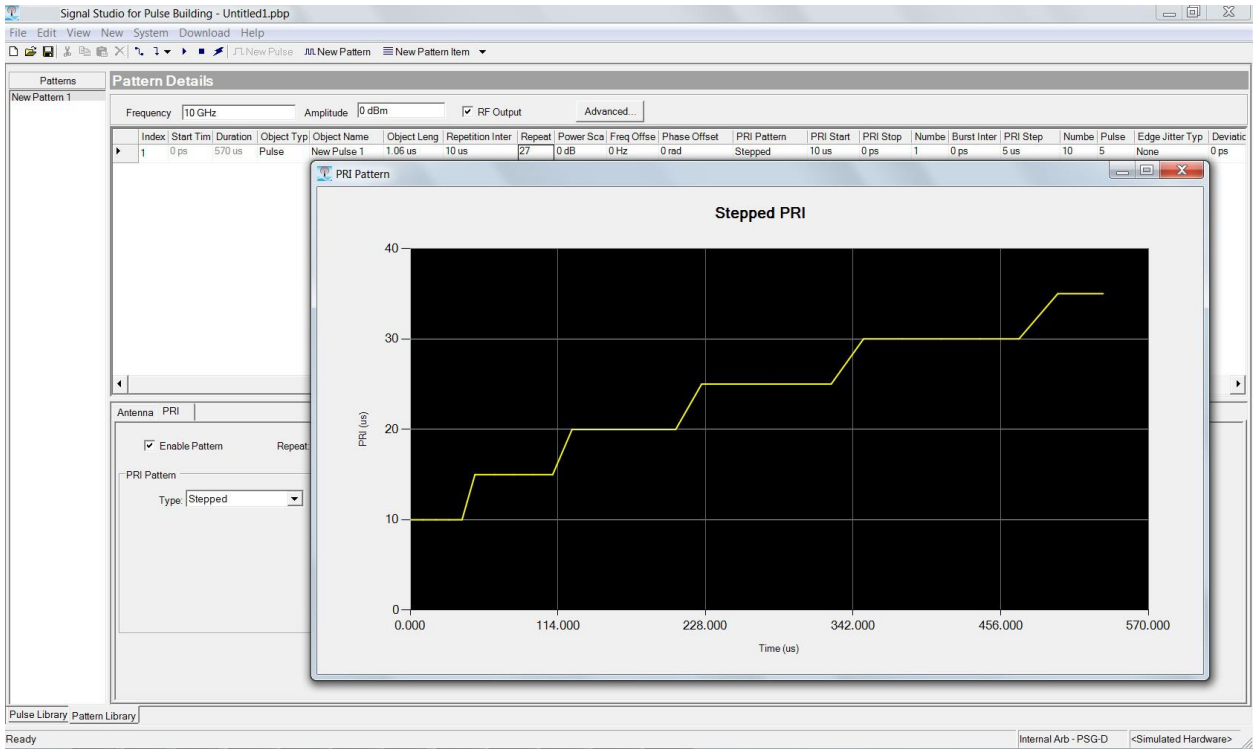

Figure 6. PRI pattern – stepped.

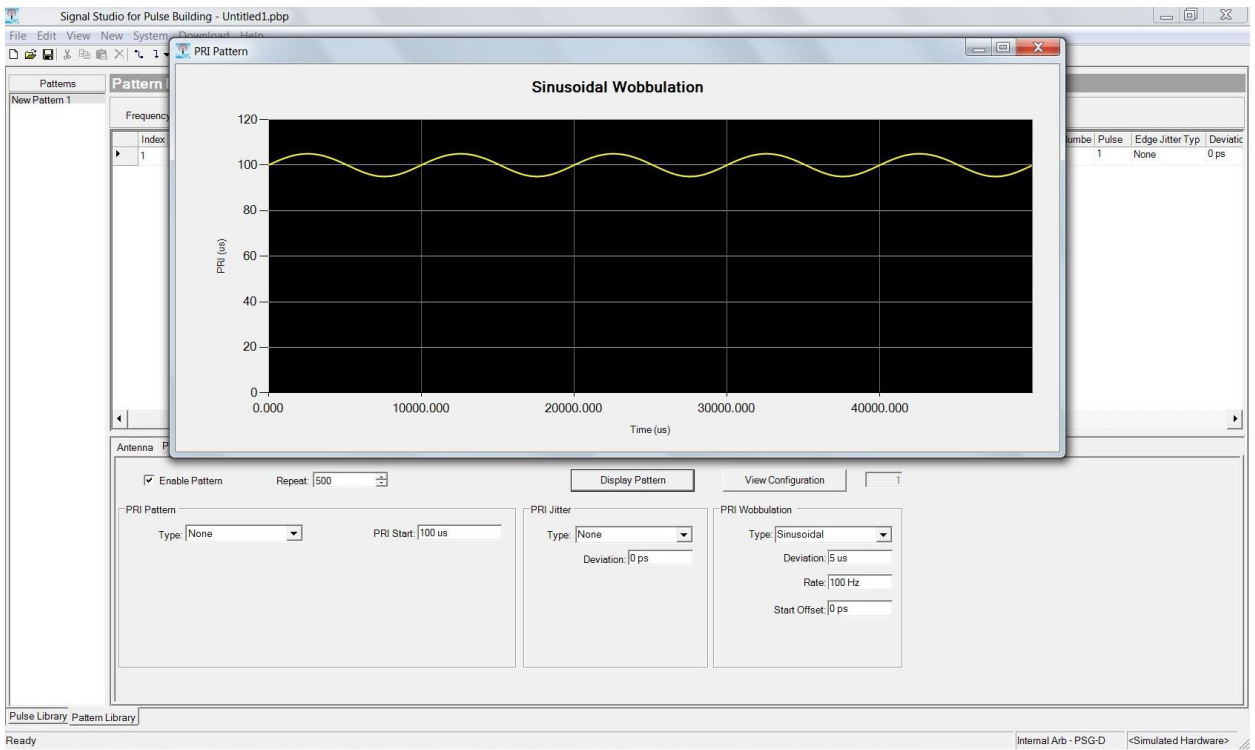

Figure 7. Sinusoidal PRI wobble.

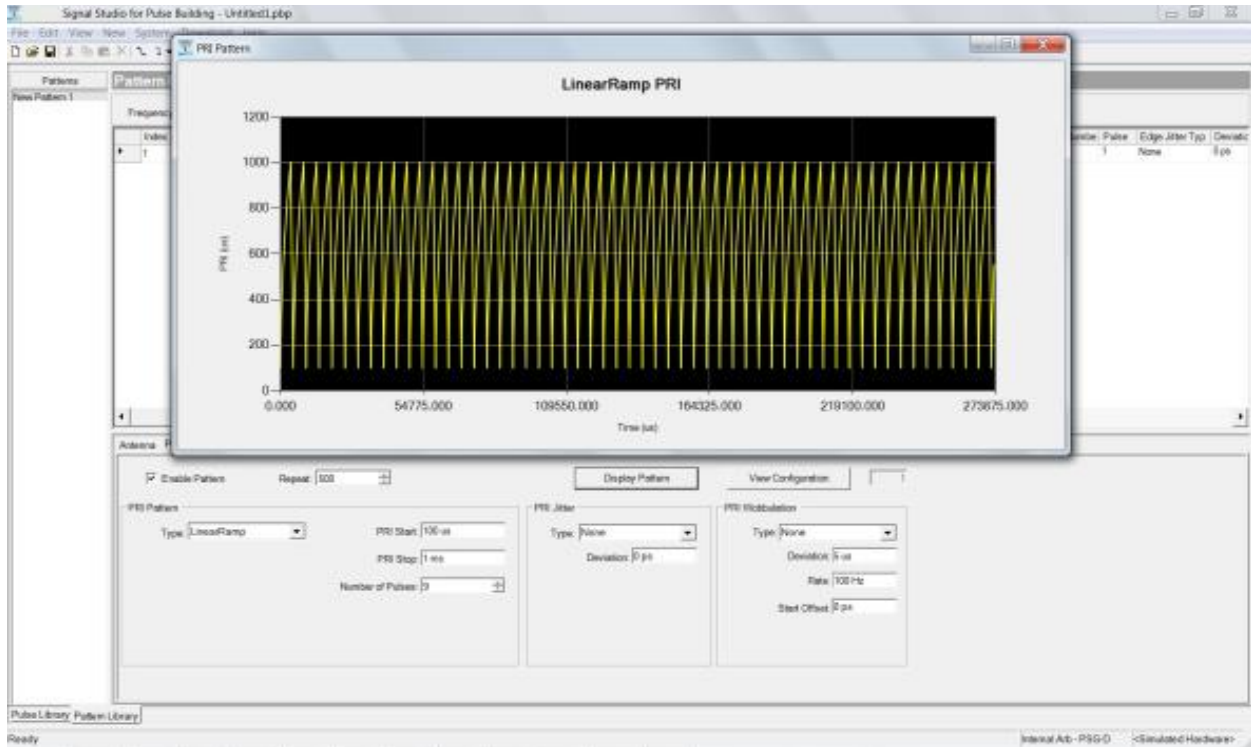

Figure 8. PRI pattern: linear ramp.

Features Summary

Pulse building	Component and transmitter test		Receiver testing		Comments
	Basic features	Advanced features	Basic features	Advanced features	
Pulse parameters					
Rise time	•		•		
Fall time	•		•		
Edge shape	•		•		
Jitter	•		•		Gaussian, uniform, or U-shaped jitter specified by jitter deviation
Pulse width pattern	•		•		Linear ramp, stepped, or staggered specified by timing parameters and number of pulses

Pulse building	Component and transmitter test		Receiver testing		Comments
	Basic features	Advanced features	Basic features	Advanced features	
Modulation-on-pulse					
AM step	•		•		Selectable amplitude offset and step size
Barker	•		•		Seven different Barker codes (2, 3, 4, 5, 7, 11, 13)
BPSK	•		•		Alternating one-zero (0° and 180°) bit pattern with user-defined step size
Custom BPSK	•		•		User-defined bit pattern (0° and 180°)
FM chirp	•	•	•	•	User-defined FM chirp deviation and offset up to ± 1 GHz
Custom (nonlinear) FM chirp	•		•		Polynomial coefficient representation of the instantaneous frequency versus time
QPSK	•		•		User-defined step size with symbols at 45°, 135°, 225°, 315°
Custom QPSK	•		•		User-defined bit pattern with phase shift in any quadrant
Polyphase codes		•		•	Frank, P1, P2, P3, P4, custom
Pattern parameters					
Number of pulse repetitions	•		•		
Pulse repetition interval	•		•		
Repetition interval jitter			•		
PRI patterns		•		•	Bursted, linear ramp, staggered, stepped
PRI jitter	•		•		Gaussian, uniform, or U-shaped jitter specified by jitter deviation
PRI wobulation		•		•	Sawtooth, sinusoidal, triangular
Amplitude scaling	•		•		
Frequency offset	•		•		
Phase offset	•		•		
Additional off time	•		•		
Antenna Scan Parameters					
Windowing functions		•		•	Rectangular, cosine, Blackman, exact Blackman, Hamming, 3 term, user defined
Antenna scan type		•		•	Circular, conical, custom, bidirectional raster, unidirectional raster, bidirectional sector, unidirectional sector

1. With M8190A arbitrary waveform generator and E8267D PSG vector signal generator.

Supported Standards and Test Configurations

Use N7620B Signal Studio for pulse building for the following radar and EW tests.

Test	Component and transmitter test		Receiver testing	
	Basic features	Advanced features	Basic features	Advanced features
Average power	•	•		
Peak power	•	•		
Duty cycle	•	•		
AM/PM conversion	•	•		
Gain compression	•			
Linearity	•	•		
Frequency accuracy	•			
Phase accuracy	•			
Rise time	•			
Fall time	•			
Pulse shape	•			
Pulse width	•			
Overshoot	•			
Amplitude ripple	•			
Pulse repetition frequency	•	•		
Modulation bandwidth	•			
Modulation accuracy	•			
Pulse compression	•			
Time budgeting	•	•		
Power multiplexing	•			
Time multiplexing	•	•		
Frequency multiplexing	•			
Electronic countermeasures	•	•		
Range gating			•	•
Velocity gating			•	•
Pulse compression			•	•
Phase detection			•	•
Sensitivity time control			•	•
Automatic gain control			•	•
Electronic counter countermeasures			•	•
PRI De-interleaving			•	•
Input scheduling			•	•

Test	Component and transmitter test		Receiver testing	
	Basic features	Advanced features	Basic features	Advanced features
Look through			•	•
Frequency set-on			•	
Threat identification			•	•
Identification correlation			•	•
Frequency			•	
Amplitude			•	
Time of arrival			•	•
Pulse width			•	
Modulation-on-pulse			•	

Performance Characteristics

Characteristic performance:

Non-warranted value based on testing during development phase of this product.

The following performance characteristics are given for two configurations:

- Internal baseband generators
- External wideband arbitrary waveform generators upconverted through the E8267D vector signal generator

Parameters

- Rise/fall times tested with 0 ns rise/fall times programmed into pulse building and 30 ns pulse widths. Values are 0-100%.
- Pulse widths tested with 30 ns rise/fall times and pulse widths of 1 sample specified by the deviation resolution. Values are 100-100%.
- On/off ratio measured with pulse building corrections applied and user-optimized IQ modulator correction. Values measured with pulse modulator off and on with 1 us rise and fall times, 50 us pulse widths, and 100 us PRIs.

Instrument	E4438C ESG internal Arb Opt 602	5172B EXG internal Arb Opts 656, UNW	N5182B MXG internal Arb Opts 657, UNW	E8267D PSG Internal Arb Opts 602, UNW	E8267D PSG Opts 16, H18, UNW N8241A arbitrary waveform generator	E8267D PSG Opts 016, H18, UNW M8190A arbitrary waveform generator Opts 14B, 002, SEQ	M9383B/M938 4B VXG Internal Arb Opts 001, ETP, QTP, F14, D05/06/10 /11/20/21
Pulse properties (pulse modulator OFF/ON)							
Frequencies	1GHz, 2 GHz, 3 GHz			3.5 GHz, 12 GHz, 18 GHz, 32 GHz			3.5 GHz, 10 GHz, 30 GHz
Rise time	30 ns/150 ns	8 ns	6 ns	10 ns	1 ns	1 ns	5 ns ^{5, 6, 9}
Fall time	30 ns/150 ns	8 ns	6 ns	10 ns	1 ns	1 ns	5 ns ^{5, 6, 9}
Minimum pulse width	30 ns	16 ns	10 ns	20 ns	1.6 ns	250 ps ² /160 ps ³	5 ns ^{5, 6, 9}
On/off ratio	60 dB/80 dB ¹	65 dB/70 dB	65 dB/70 dB	60 dB/80 dB	65 dB/75 dB	65 dB ¹	80 dB (nom.)
Modulation-on-pulse							
Maximum chirp deviation	± 40 MHz	± 60 MHz	± 80 MHz	± 40 MHz	± 500 MHz	± 1 GHz	± 1 GHz ^{6, 9} / ± 500 MHz ⁷ / ± 250 MHz ⁸
Modulation-on-pulse							
Minimum PRI	600 ns	400 ns	300 ns	600 ns	102 ns	30 ns ² /20 ns ³	20 ns ^{6, 9, 10}
Deviation resolution	10 ns	6.7 ns	5 ns	10 ns	800 ps	125 ps ² /83 ps ³	390.625 ps ⁶ / 781.25 ps ⁷ / 1.5625 ns ⁸
Maximum pulse width 32 bit OS, 4 GB RAM (limited by Windows memory)	140 ms	140 ms	70 ms	140 ms	11.2 ms	3.5 ms	
Maximum pulse width 64 bit OS, 8 GB RAM (limited by arb waveform memory)	671 ms	671 ms	671 ms	671 ms	13.4 ms	33.5 ms ⁴	50 ms ⁴
Max unique pulses per pattern	16384	2 million	2 million	16384	32768	26214	2 million
Waveform Granularity	1 sample	1 sample	1 sample	1 sample	1 sample	1 sample	1 sample ¹¹
Frequency offset range	± 40 MHz	± 60 MHz	± 80 MHz	± 40 MHz	± 500 MHz	± 1 GHz	± 1 GHz ⁶ / ± 500 MHz ⁷ / ± 250 MHz ⁸
Phase offset range	± 180°	± 180°	± 180°	± 180°	± 180°	± 180°	± 180°

1. Pulse width: 50 us PRI: 100 us
2. Option 14B (8 Gsa/s)
3. Option 12G (12 Gsa/s)
4. Limited by .NET array size, not by arb waveform memory
5. RF Blanking disabled
6. Baseband Option D20 or D21
7. Baseband Option D10 or D11
8. Baseband Option D05 or D06
9. Output Frequency > 3.2 GHz
10. The minimum pattern period is 4 us. The minimum PRI requires multiple pulses in the pattern.
11. The total pattern period must end on a multiple of 32 samples. Pulse Building pads the last pulse PRI to ensure this condition is next.

Ordering Information

Software licensing and configuration

Signal Studio offers flexible licensing options, including:

- Fixed license: Allows you to create unlimited I/Q waveforms with a specific Signal Studio product and use them with a single, specific platform.
- Transportable license: Allows you to create unlimited I/Q waveforms with a specific Signal Studio product and use them with a single platform (or PC in some cases) at a time. You may transfer the license from one product to another.
- Waveform license: Allows you to generate up to 545 user-configured I/Q waveforms with any Signal Studio product and use them with a single, specific platform.

The table below lists fixed, perpetual licenses only; additional license types may be available. For detailed licensing information and configuration assistance, please refer to the Licensing Options web page at www.keysight.com/find/SignalStudio_licensing

N7620B signal studio for pulse building

Model Option	Description
Connectivity	
N7620B-9FP/9TP	Connect to M9383B/M9384B VXG signal generator
N7620B-1FP	Connect to E4438C ESG signal generator
N7620B-2FP	Connect to E8267D PSG signal generator
N7620B-3FP	Connect to N5182B/72B MXG/EXG signal generator
N7620B-AFP	Connect to M8190A external baseband generator (also with PSG and wideband IQ)
N7620B-DFP	Connect to N603X/M933X/N8241A/N8242A external baseband generator (also with PSG wideband IQ)
Capability	
N7620B-EFP	Basic features include fixed PRIs, pulse widths, and modulation-on-pulse. Option EFP also features phase, frequency, and amplitude offsets
N7620B-QFP	Advanced features include PRI patterns and wobulation, pulse width patterns and wobulation, antenna scans and antenna patterns. Option QFP also includes the ability to import and export from a spreadsheet using a CSV (comma separated variables) file format. Requires option EFP. Option is available with any connectivity option



Try Before You Buy

Free 14-day trials of Signal Studio software provide unrestricted use of the features and functions, including signal generation, with your compatible platform. Redeem a trial license online at

www.keysight.com/find/SignalStudio_trial

Hardware Configurations

To learn more about compatible hardware and required configurations, please visit:

www.keysight.com/find/SignalStudio_platforms

PC Requirements

A PC is required to run Signal Studio.

www.keysight.com/find/SignalStudio_pc

Additional Information

Websites

Access the comprehensive online documentation, which includes the complete software HELP, download the software, and request a trial license.

www.keysight.com/find/n7620b

www.keysight.com/find/SignalStudio

Literature

- Keysight E8267D PSG Vector Signal Generator, Data Sheet, 5989-0697EN
- Keysight N5182B MXG Vector Signal Generator, Data Sheet, 5991-0038EN
- Keysight N5172B EXG Vector Signal Generator, Data Sheet, 5991-0039EN
- Keysight E4438C ESG Vector Signal Generator, Data Sheet, 5988-4039EN
- Keysight M8190A Arbitrary Waveform Generator, Data Sheet, 5990-7516EN
- Keysight N8241A Arbitrary Waveform Generator, Technical Overview, 5989-2595EN
- Keysight M9330A Arbitrary Waveform Generator, Data Sheet, 5990-6426EN
- Keysight N6030A Arbitrary Waveform Generator, Technical Overview, 5889-1475EN
- Keysight M9384B and M9383B, Microwave Signal Generators, Data Sheet, 5992-4260EN

Learn more at: www.keysight.com

For more information on Keysight Technologies' products, applications or services, please contact your local Keysight office. The complete list is available at: www.keysight.com/find/contactus

