

Keysight M9352A

PXI Hybrid Amplifier/Attenuator

Data Sheet

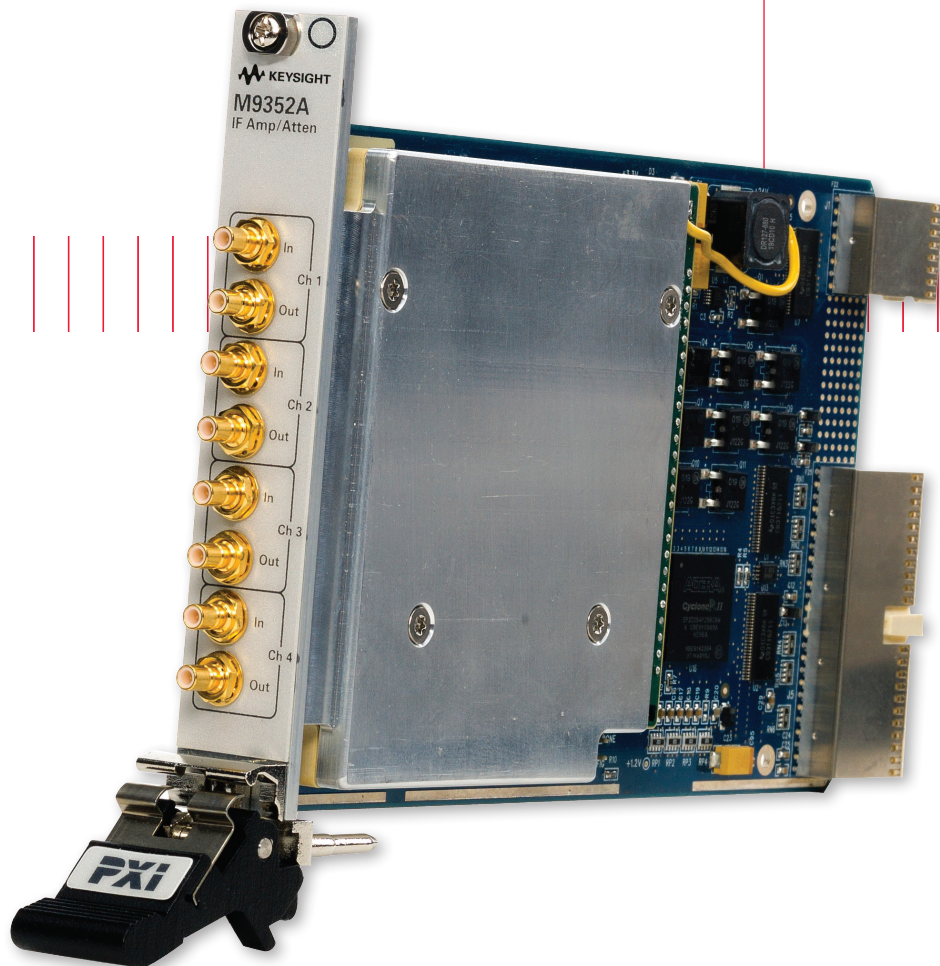

Overview

Introduction

The Keysight Technologies, Inc. M9352A Amplifier/Attenuator is optimized for use with Keysight's newest PXI multichannel M9362A-D01 Quad Downconverter for applications such as multi-channel coherent signal analysis, radar, SIGNIT, ELINT, MASINT, EW signal capture and analysis, RF and microwave recording and analysis.

Product description

The Keysight M9352A is a one-slot, 4-channel, PXI Hybrid IF Amplifier/Attenuator with 1 GHz analog bandwidth providing excellent IF signal conditioning for use in multi-channel modular solutions. Combine with the M9362A-D01 PXIe Quad Downconverter, up to four M9202A IF Digitizers, and a local oscillator for multi-channel wideband signal capture.

Applications

- Aerospace and defense
- Wireless communications
- Radar and wideband signal capture

Features

- 10 MHz to 1 GHz
- 4 channels
- 1 GHz bandwidth
- Fast IF power control with 31.5 dB solid state IF attenuator with 0.5 dB steps
- Chassis slot compatibility: cPCI (J1), PXI-1, PXIe hybrid
- PXI Hybrid form factor

Customer values

- Multiple programmatic interfaces enable easy integration into existing test environments and reduced development time
- Included drivers, soft front panels, and programming examples
- Software support for easy integration
- Conforms to Modular Open Systems Approach (MOSA)

Easy Setup ... Test ... and Maintenance

Hardware platform

Compliance

The M9352A is PXI hybrid compliant, using either a cPCI (J1), PXI-1, or PXIe hybrid slot. Designed to benefit from fast data interfaces, the products can be integrated with other test and automation modules in cPCI(J1), PXI-1, or PXIe hybrid chassis slots. The PXI format offers high performance in a small, rugged package. It is an ideal deployment platform for many automated test systems. A wide array of complementary PXI products are currently available. Products include multimeters, waveform generators, local oscillators, digitizers, and switch multiplexers.

Software platform

IO Libraries

Keysight IO Libraries Suite offers FAST and EASY connection to instruments and the newest version extends that capability to include modular instruments.

NEW support for PXI. The Keysight IO Libraries Suite helps you display ALL of the modules in your system, whether they are PXI, PXIe, or PCIe. From here you can view information about the installed software or start the module's soft front panel. Launch the module's soft front panel directly from Keysight Connection Expert.

NEW easy way to find the right driver from Keysight Connection Expert.

Drivers

Keysight provides instrument drivers that work with your choice of software, saves time, and preserves software and hardware investments. Keysight modular instruments come with IVI-COM, IVI-C, LabVIEW and MATLAB software drivers that work in the most popular T&M development environments including, VisualStudio (VB.NET, C#, C/C++), VEE, LabVIEW, LabWindows/CVI, and MATLAB.

With the multiple drivers included and minimum software adjustments, any Keysight PXI module can be swapped out, replaced, or upgraded with the latest PXI module.

Easy software integration

Included are application code examples for VisualStudio (VB.NET, C#, C/C++), VEE, LabVIEW, LabWindows/CVI, and MATLAB, which provide set up functionality. These application code examples are easily modified to quickly integrate the module into your measurement system.

Software applications

Keysight soft front panels provide easy to use instrument communications for diagnostics and basic hardware setup. The M9352A's graphical user interface guides developers through module setup. Users can quickly configure the instrument parameters. The M9352A supports interfaces for VisualStudio, VEE, MATLAB, and LabVIEW. The interfaces are implemented using the IVI standard supporting both IVI-COM and IVI-C.

The M9352A soft front panel monitors and controls the amplifier/attenuator with the following functions:

- Setting gain values
- Monitoring hardware states

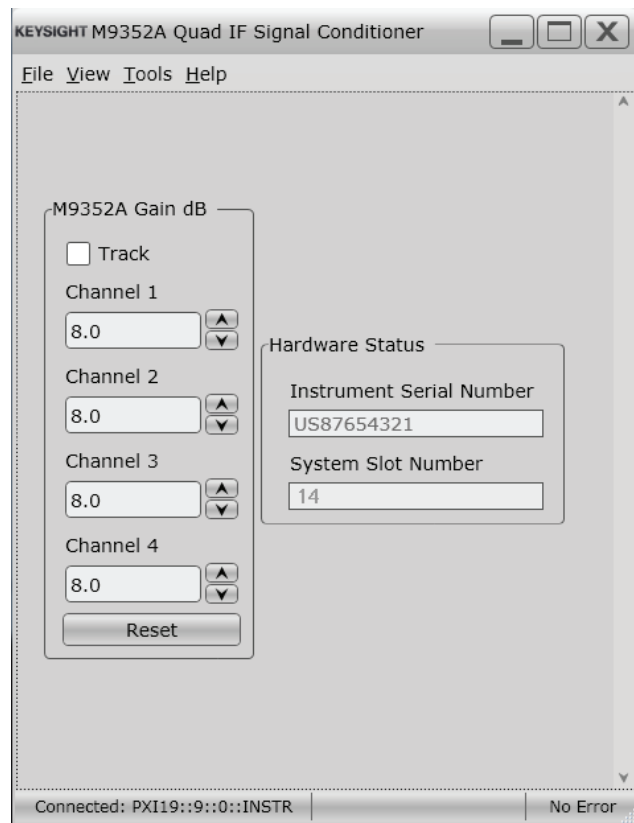

Figure 1. Keysight M9352A PXI hybrid Amplifier/Attenuator, software interface

Calibration intervals

The M9352A does not require annual calibration.

Technical Specifications and Characteristics

All specifications are nominal unless otherwise noted.

General

Number of Channels	4
Bandwidth	1 GHz
Noise Figure	3 dB
Input TOI	+43 dBm

Amplification

Minimum Gain	≥ 5 dB
Maximum Gain	≥ 36 dB
Gain Steps	0.5 dB
Gain Range	31.5 dB
Maximum SWR	2.5 (50 MHz–900 MHz)
Input coupling	AC
Input Impedance	50 Ω
Input Voltage Range	
Max Voltage Range:	1 V p-p
Damage Level:	+20 dBm
Channel to channel isolation	>60 dB

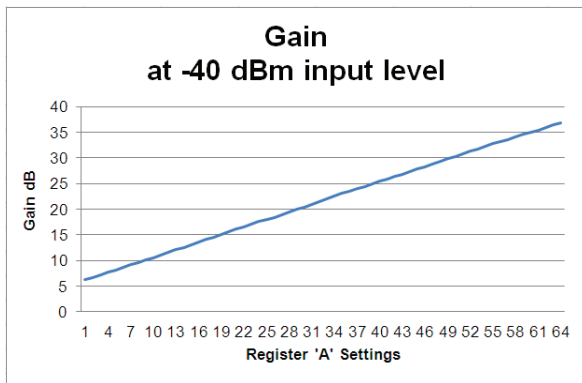

Figure 2. Keysight M9352A PXI hybrid Amplifier/Attenuator, gain

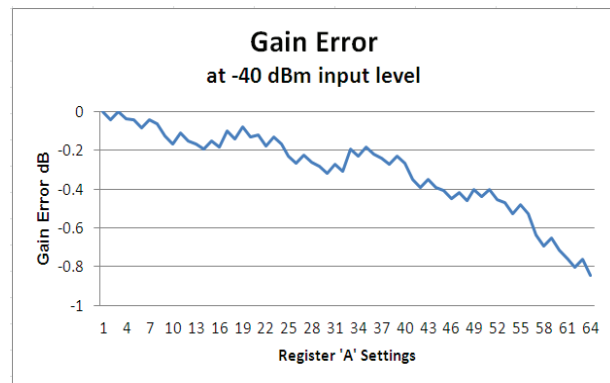

Figure 3. Keysight M9352A PXI hybrid Amplifier/Attenuator, gain error

Technical Specifications and Characteristics

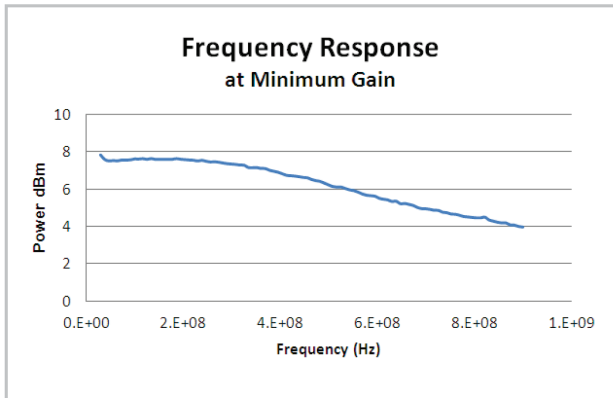

Figure 4. Keysight M9352A PXI hybrid Amplifier/Attenuator, frequency response at minimum gain

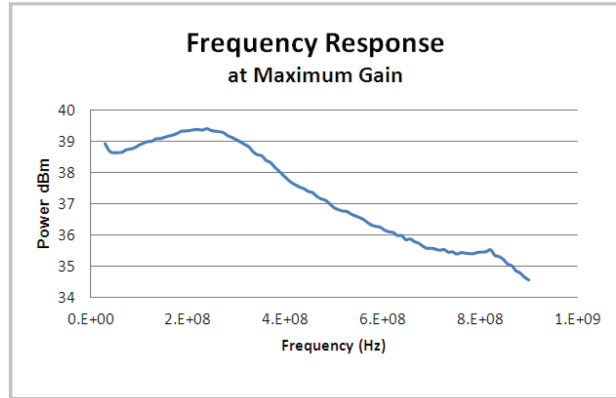

Figure 5. Keysight M9352A PXI hybrid Amplifier/Attenuator, frequency response at maximum gain

Environmental and Physical Specifications

Temperature Range	Operating	23° C ± 5° C		
	Non-operating	-40° C to + 70° C		
Connectors	All connectors	SMB		
EMC		Complies with European EMC Directive 2004/108/EC IEC/EN 61326-2-1 CISPR Pub 11 Group 1, class A AS/NZS CISPR 11 ICES/NMB-001 This ISM device complies with Canadian ICES-001. Cet appareil ISM est conforme a la norme NMB-001 du Canada.		
Warm-up time		30 minutes, max		
Power dissipation				
	+3.3 V	+5 V	+12 V	-12 V
	0.5 A	0.02 A	1.3 A	0 A
				Total Power
				17.4 Watts

Size

Dimensions	3U/1-slot PXI hybrid Chassis slot compatibility: CPCI(J1), PXI-1, PXIe hybrid Front panel complies with IEEE 101.10 certification and compliance			
Weight	1 lb/0.4 kg			

Technical Specifications and Characteristics

All specifications are nominal unless otherwise noted.

System requirements		
Operating systems	Windows XP, Service Pack 3 or later (32-bit)	Windows 7 (32-bit and 64-bit) Starter, Home Basic, Home Premium, Professional, Ultimate, Enterprise
Processor speed	600 MHz or higher required 800 MHz recommended	1 GHz 32-bit (x86), 1 GHz 64-bit (x64), no support for Itanium 64
Available memory	256 MB minimum (1 GB or greater recommended)	1 GB minimum
Available disk space 1	1.5 GB available hard disk space, includes: 1 GB available for Microsoft.NET Framework 3.5 SP12 100 MB for Keysight IO Libraries Suite	1.5 GB available hard disk space, includes: 1 GB available for Microsoft.NET Framework 3.5 SP12 100 MB for Keysight IO Libraries Suite
Video	Super VGA (800x600) 256 colors or more	Support for DirectX 9 graphics with 128 MB graphics memory recommended (Super VGA graphics is supported)
Browser	Microsoft Internet Explorer 6.0 or greater	Microsoft Internet Explorer 7 or greater

1. Because of the installation procedure, less memory may required for operation than is required for installation.
2. NET Framework Runtime Components are installed by default with Windows Vista and Windows 7. Therefore, you may not need this amount of available disk space

Definitions for specifications

Specifications describe the warranted performance of calibrated instruments that have been stored for a minimum of 2 hours within the operating temperature range of 0 to 55°C, unless otherwise stated, and after a 45 minute warm-up period. Data represented in this document are specifications unless otherwise noted.

Characteristics describe product performance that is useful in the application of the product, but that is not covered by the product warranty. Characteristics are often referred to as Typical or Nominal values. Characteristic are represented in italics.

- **Typical** describes characteristic performance, which 80% of instruments are expected to meet when operated over a 20 to 30°C temperature range. Typical performance is not warranted.
- **Nominal** describes representative performance that is useful in the application of the product when operated over a 20 to 30°C temperature range. Nominal performance is not warranted.

Note: All graphs contain measured data from several units at room temperature unless otherwise noted

Configuration and Ordering Information

Software Information

Supported operating systems	Microsoft Windows XP (32-bit) Microsoft Windows 7 (32/64-bit)
Standard compliant drivers	IVI-COM, IVI-C, LabVIEW, MATLAB
Supported application development environments (ADE)	VisualStudio (VB.NET, C#, C/C++), VEE, LabWindows/CVI, MATLAB
Keysight IO Libraries	Includes: VISA Libraries, Keysight Connection Expert, IO Monitor

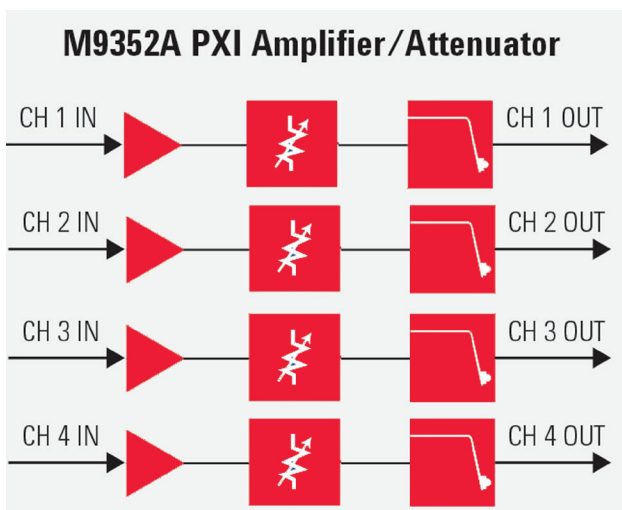

Figure 6. Block diagram of M9352A PXI 4-channel amplifier/attenuator module

Ordering Information

Model	Description
M9352A	PXI Amplifier/Attenuator Module: 1 GHz (includes option-H01 custom configuration)
Related Products	
M9018A	18-slot PXIe Chassis
M9036A	PXIe Embedded PC Controller
M9202A	PXIe IF Digitizer: 12-bit, 2 GS/s (with options CO1, FO2, MO5, DDC)
M9202A-V05	50 MHz BW Streaming
M9202A-V10	100 MHz BW Streaming
M9302A	PXI Local Oscillator: 3 GHz to 10 GHz
M9362A-D01	PXIe Quad Downconverter: 10 MHz to 26.5 GHz (custom configuration)
M9362AD01-CA1	IF Jumper Cables for use with 4-M9202A Single CH Digitizers
M9362AD01-CA2	IF Jumper Cables for use with 2-M9202A Dual CH Digitizers
M9362AD01-CA3	IF Jumper Cables for use with the M9210A
M9362AD01-CA4	LO Interconnect Kit for use with the M9302A
Accessories	
Software, example programs, product information on CD (included)	
SMB to SMA Cables (eight included)	

